

39G GALAXY



MS ISO 14001 CERT. NO. C003001129



MS ISO 9001 REG. NO. AR 0239



CISB 39G offers...

- Units are designed in accordance to
 - ARI Standard for Coils (ARI 410)
 - ASHRAE Standard for Drain Pan (ASHRAE 62-89)
- Double Wall with 1", 2" & 3" 40kg/m³ CFC-Free PU Insulation (HCFC 141b). Isolates Insulation Exposure to the Air Stream.
- Wide range of Coils offering – 4, 5, 6, 7, 8 Rows and 8, 10, 12, 14 FPI for Chilled Water. Optimized coil circuiting . DX Coil and Hot Water Coil are also available.
- All Chilled Water and DX Coils are Factory Pressure Tested at 400 psig as standard.
- Coil tracks enable easy coil removal for complete cleaning and assurance of a dry unit interior.
- Powder painted sloped galvanized steel drain pan with bottom drainage.
- Forward Curved and Backward Curved (Airfoil Blade) Fan
 - Forward Curved - Sizes 160 ~ 1000mm Diameter
 - Backward Curved (Airfoil Blade) – Sizes 225 ~ 1000mm Diameter
- Low leak construction with hex socket compression, type latch assemble and ribseals on mating panel perimeter.
- Factory installed unit base of 100mm height. constructed of 14 Gauge Galvanized Steel.

50mm NTB Features :

- Composite Corner Piece (Trileg) - Nylon 6 + 30% Glass filled.
- Non Thermal Bridge Aluminium Frame Extrusion.
- Non Thermal Bridge Sandwiched Panels and Access Doors.
- Non Thermal Bridge Quality Panel to Frame Fitting.
- No condensation problems in humid environments at low internal temperatures.
- Hygienic : due to smooth internal and external surface.
- Rigid construction with aluminium framework and machine injected rigid polyurethane foam panels.
- Spring-mounted fans for low vibration transmission.
- Dry, Corrosion Free construction.



Compression Latch (Hex Socket)

Only requires the use of hexagon wrench to open / close the access door.



Chilled Water Coil With Steel Header (CU and Alu Fin)

Coils are of aluminium / copper plate fins with belled collars and bonded to 12.7mm OD copper tubes by mechanical expansion. The coils have galvanised steel casing and steel headers with male threaded connections.

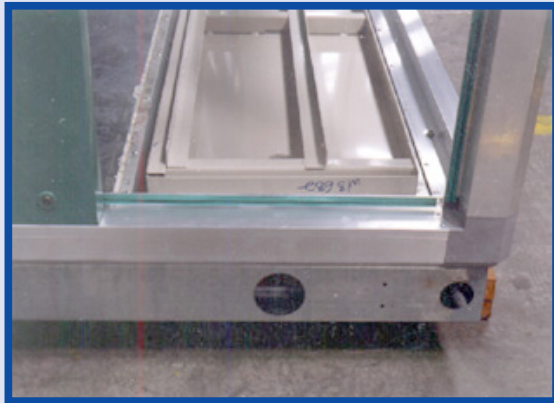

Sloping Drain Pan and Drain Outlet

New drain pan assembly for better drainage, bottom access drain and sloping for rapid waterflow and better Internal Air Quantity (IAQ). Ready to couple with female connection.



Direct Expansion Coil (DX Coil)

Coils are of aluminium / copper with belled collars and bonded 12.7mm OD copper tubes by mechanical expansion. Coils are provided with brass distributors with sweat type connections.

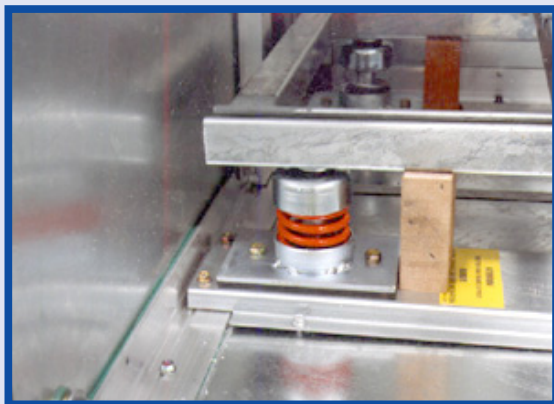

Isolator Spring

As standard from the factory, the fan and motor assembly are mounted on a common base with colour-coded internally mounted spring isolators, which saves site installation cost.



Assembly Fan Housing Motor and Base

FMB are made of painted heavy gauge galvanized steel (for 39G1422 and above) or power strut type (for 39G0508 to 39G1319) to ensure proper and easy of installation fan housing and motor.

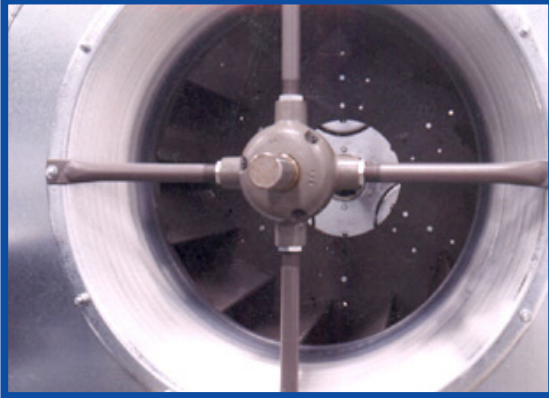

Bearing Arm

Self aligning double row ball bearings mounted within a cast iron housing supported on tubular bearing arm assembly.



Taper Lock Pulley

Ability to change diameter of pulley according to fan shaft. Pulleys with taper lock bush allows for convenient dismantling and maintenance of drive package, besides offering flexibility in interchanging for different shaft sizes.

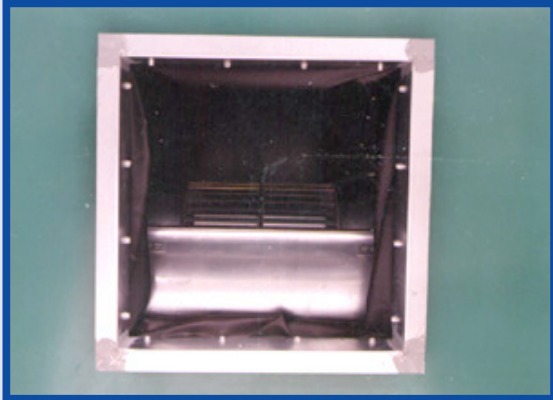

Fan Discharge Collar

Flanged discharge collar to provide easy ducting connection.



Handle Grab

Large and Non-Conductive handles for easy panel removal.



Accessory High Velocity Filter (HVF) Frame

For "free air return" application, factory supplied 75mm HVF track is an option instead of one module casing resulting in shorter overall unit length.



Dampers

Mixing boxes are equipped with parallel blades interconnected outside with return air dampers.

Guide Specifications for 39SR 50mm Non-Thermal Bridge (NTB) AHU

Panel Design

- Panels shall be formed to produce solid 50mm double walled thermal break design of modular dimensions. There shall be a thermal break between the exterior and internal panels. Exterior panels shall be fabricated from 0.50mm thickness pre-painted steel, in accordance to JIS G3312 SGC570 Z18 or equivalent. The coating shall meet or exceed ASTM B117 Standard for Salt Spray Resistance at 500 hours. Interior panels shall be fabricated from solid 1.00mm galvanized sheet steel, in accordance with JIS G3302 SGCC Z27 or equivalent [1.00mm SUS 304 Stainless Steel - optional]. Both exterior and interior panels shall be formed and reinforced to provide rigid construction.
- All panels to be insulated with machine-injected rigid polyurethane foam with a minimum density of 40kg/m³ and thermal conductivity K-factor of 0.019W/m.K in accordance with JIS A9514 (PU panel class 0).
- Panels shall be of one-piece design to facilitate removal. Panels shall be assembled with mechanical fasteners such that each panel is individually removable. The fasteners shall be zinc-chromate plated [SUS 304 stainless steel - optional].
- Panels shall have no exterior exposed raw edges that could lead to rust formation. The side perimeter of external panel shall include a built-in PVC gasket acting as air seal. Panels shall come with removable polyethylene protective sheet to protect external surfaces from scratches and allow for removal at job site.

Casing Construction

- Casing construction shall be Non-Thermal-Bridge (NTB) with no direct metal-to-metal contact between the internal and external surfaces. The unit frame construction shall consist of nylon glass-fiber reinforced corner-joints that connect extruded aluminium thermal break profiles. The extruded aluminium thermal break profiles shall consist of a complete structure fabricated from high strength engineering thermoplastic bars that separates the aluminium outer and inner profiles. The aluminium frames shall be gasketed along the perimeter with closed cell heavy duty neoprene rubber gasket located in between panels and the aluminium frames. The frame shall be constructed to permit removal of the panels without affecting the structural integrity of the unit.
- Corner pieces (Tri-leg) molded of composite material forms the final integral part of the casing instruction. The non-metallic construction of the corner pieces enhances the Non-Thermal-Bridge feature of the AHU casing.
- Unit casing construction shall be tested to conform to the following standard:
BS EN 1886:1998 or DIN EN 1886:1998 Ventilation for buildings – Air Handling Units – Mechanical performance

The construction shall satisfy the minimum requirements according to the classification in BS EN 1886:1998 or DIN EN 1886:1998 as shown below:

Mechanical Characteristics	Class
Casing strength	2
Casing air leakage under -400 Pa	B
Casing air leakage under +700 Pa	A/B *
Filter bypass leakage	F9
Thermal transmittance	T2
Thermal bridging factor	TB2

Note: Class B achievable upon request with special construction

Access Doors

- Access doors shall be constructed from double walled thermal break panels insulated with the same material as the casing panels. The four sides of the access door shall be covered permanently with extruded PVC to ensure non-metallic thermal break.
- Door frames shall be constructed of a single-piece fiberglass construction for Non-Thermal-Bridging (NTB). The internal flange of the door frame shall be sealed along the perimeter with replaceable closed cell neoprene gasket of minimum 5.0mm thickness for air tightness and thermal performance.
- The door latch shall consist of a single-piece construction consisting of a handle with opening and closing mechanism fabricated from nylon glass fiber reinforced thermoplastic with thermal break design. The locking of the access door shall be achieved via a single-piece graduated cam-lock with stopper for air-tightness.
- Door hinges shall be fabricated from nylon glass fiber reinforced thermoplastic and installed with no direct contact with the internal surface of the air handling unit. The hinges shall permit a complete 180° door swing

Basic Construction

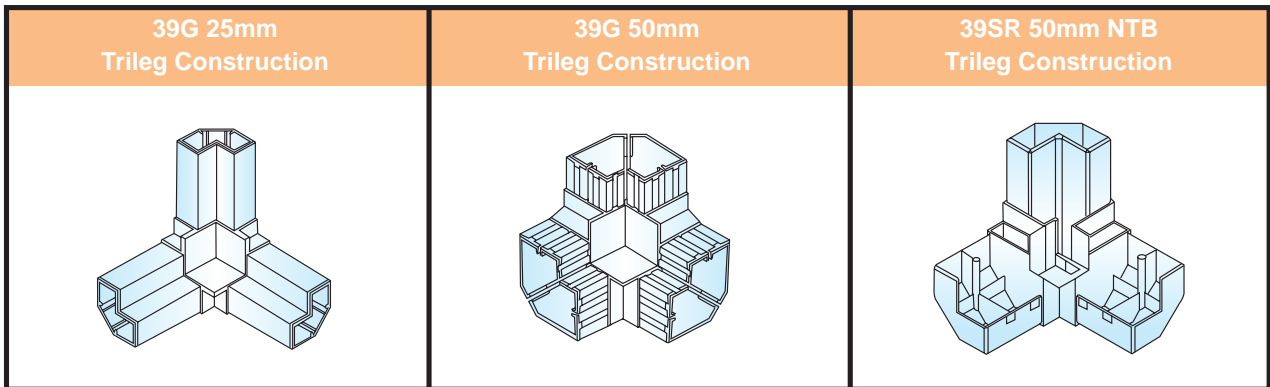
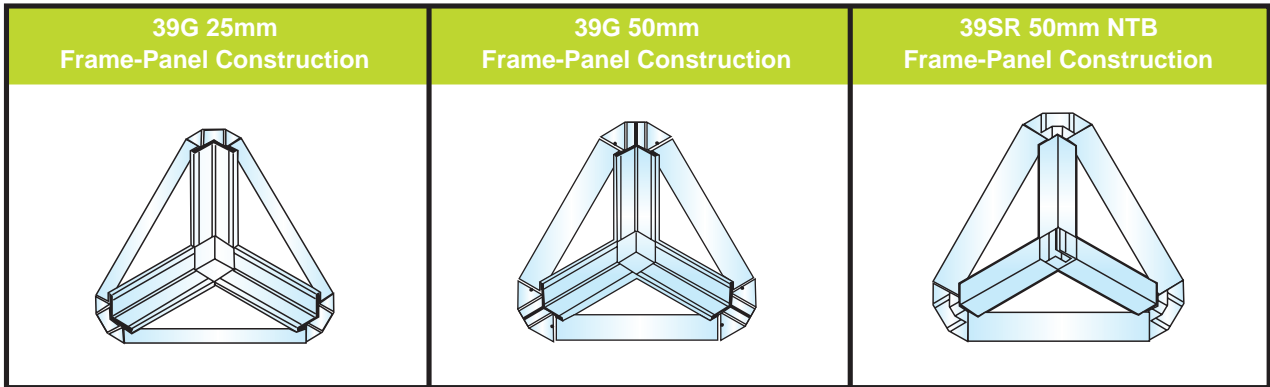
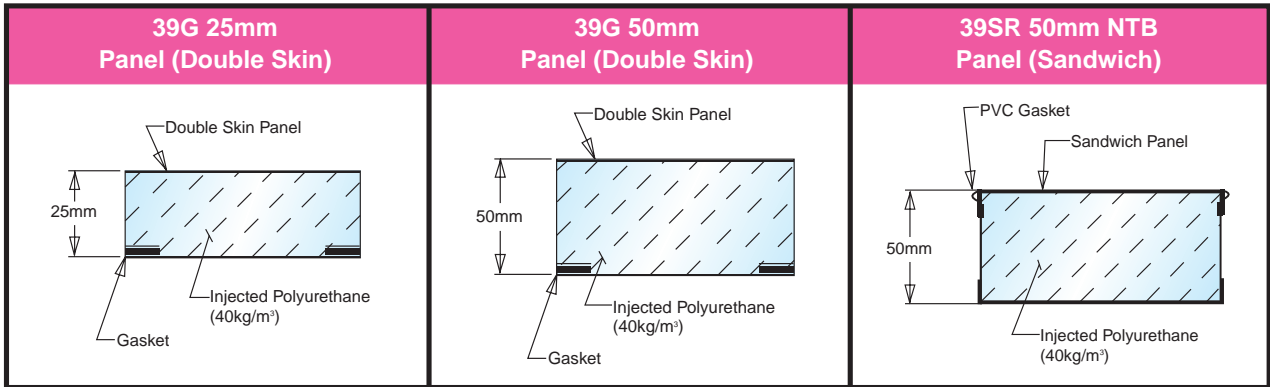
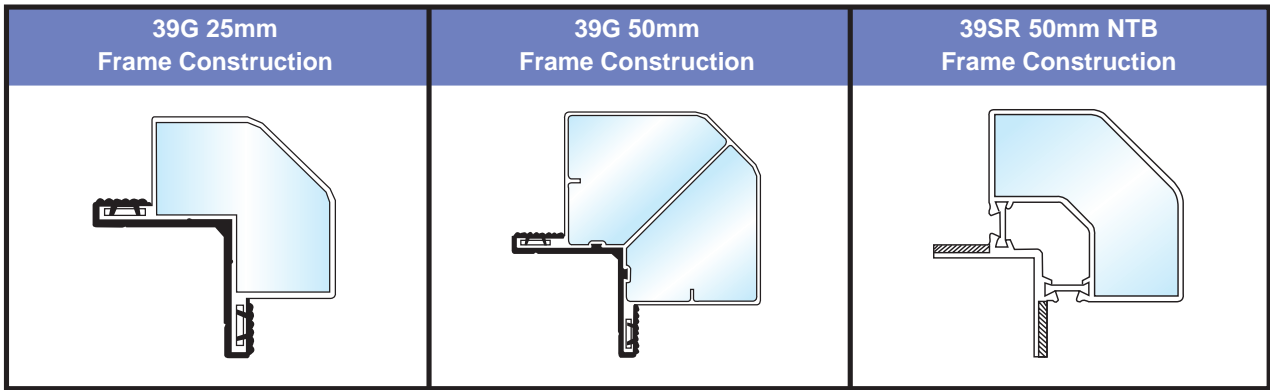

Quick Selection Chart

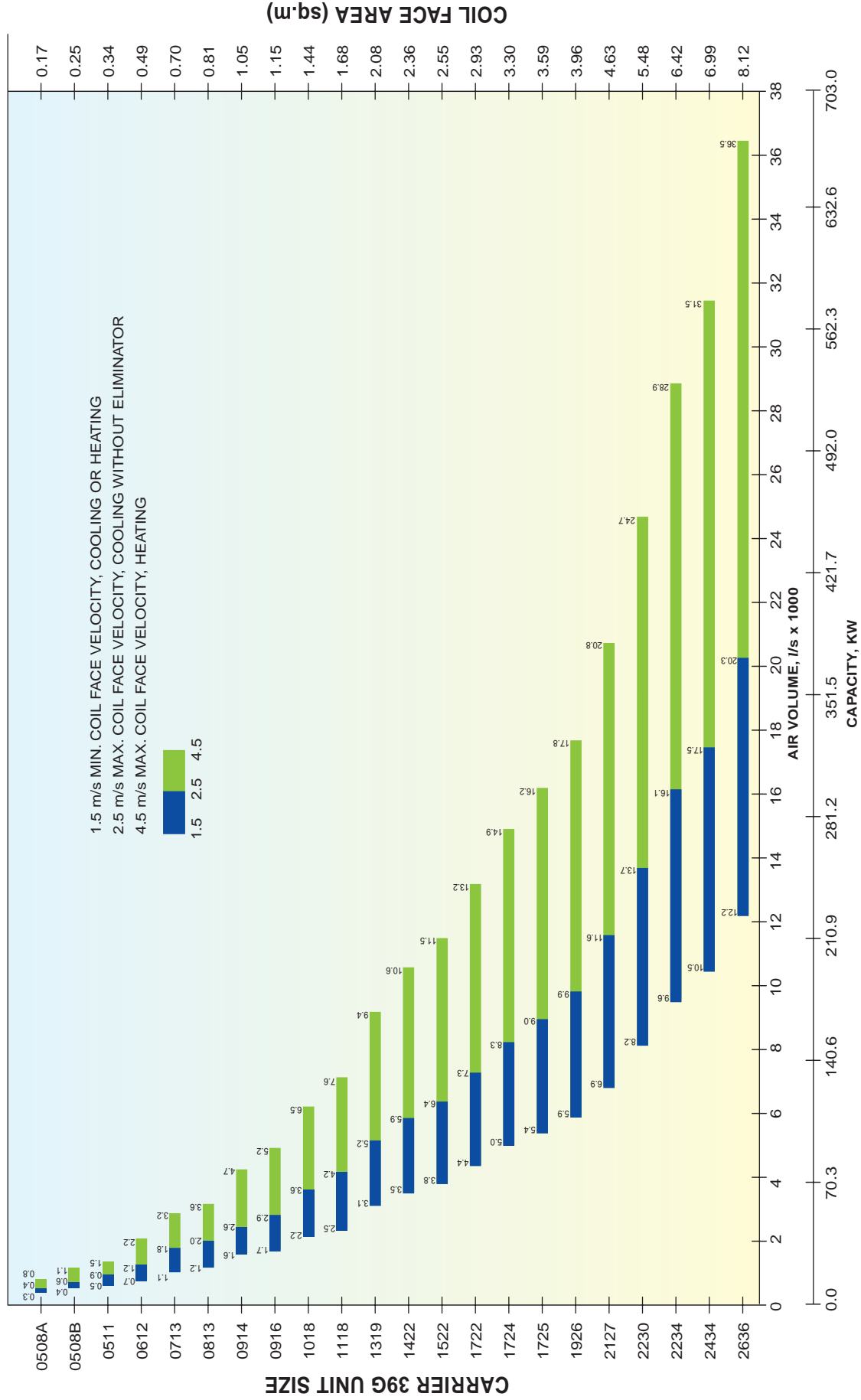

Note: For Chilled Water application between 2.5 & 3.15m/sec. face velocity, the use of Drift Eliminator is necessary.

Dimension

Unit Size	Fan Size	Range Of Hp	Nominal Capacity (kW)	Nominal A/Flow @2.5m m/s	Section Length							Unit HH* (mm)	Unit Width (mm)	Unit HV** (mm)
					MXB (G)	Filter			Access (C)	Coil (B)	Fan (A)			
						HVF (F)	LVF (E)	BF (D)						
0508A	FCG 02-160	1 ~ 1.5	7.9	425	600	300	600	600	600	500	500	500	800	1000
	FCG 02-180	1.5 ~ 2												
0508B	FCG 02-180	1.5 ~ 2	11.4	614	600	300	600	600	600	500	500	500	800	1000
0511	FCG 02-200	1.5 ~ 3	15.8	850	600	300	600	600	600	500	600	500	1100	1000
0612	FCG 02-225	2 ~ 4	22.9	1227	600	300	600	600	600	500	600	600	1200	1200
	BCG 12-225	3 ~ 5												
0713	FCG 02-280	3 ~ 5	32.5	1746	600	300	600	600	600	500	700	700	1300	1400
	BCG 02-280	4 ~ 7.5												
0813	FCG 02-315	4 ~ 5	37.8	2030	600	300	600	600	600	500	800	800	1300	1600
	BCG 12-315	5 ~ 7.5												
0914	FCG 02-355	4 ~ 7.5	48.8	2620	600	300	600	600	600	500	900	900	1400	1800
	BCG 12-355	5 ~ 10												
0916	FCG 02-355	4 ~ 7.5	53.6	2879	600	300	600	600	600	500	900	900	1600	1800
	BCG 12-355	7.5 ~ 15												
1018	FCG 02-400	5 ~ 10	66.8	3587	600	300	600	600	600	500	1000	1000	1800	2000
	BCG 15-400	7.5 ~ 15												2100
1118	FCG 05-450	7.5 ~ 15	78.2	4201	600	300	600	600	600	500	1000	1100	1800	2200
	BCG 15-450	10 ~ 15												
1319	FCG 05-450	7.5 ~ 15	96.7	5192	600	300	600	600	600	500	1000	1300	1900	2400
	BCG 15-450	10 ~ 15												2500
	FCG 05-500	10 ~ 20												2600
	BCG 15-500	15 ~ 20												2700
1422	FCG 05-500	10 ~ 15	109.8	5900	900	300	600	600	600	500	1100	1400	2200	2600
	BCG 15-500	10 ~ 15												2700
	FCG 02-560	15 ~ 20												2800
	BCG 15-560	15 ~ 20												3000
1522	FCG 02-560	10 ~ 20	118.6	6372	900	300	600	600	600	500	1200	1500	2200	2800
	BCG 15-560	15 ~ 20												3000
	FCG 02-630	15 ~ 25												3200
	BCG 15-630	20 ~ 25												3300
1722	FCG 02-630	15 ~ 20	136.2	7316	900	300	600	600	600	500	1400	1700	2200	3200
	BCG 15-630	15 ~ 25												3300
	FCG 02-710	20 ~ 25												3400
	BCG 15-710	20 ~ 30												3500
1724	FCG 02-630	15 ~ 25	153.6	8280	900	300	600	600	600	500	1400	1700	2400	3200
	BCG 15-630	15 ~ 25												3300
	FCG 02-710	20 ~ 30												3400
	BCG 15-710	20 ~ 30												3500
1725	FCG 05-630	15 ~ 25	166.9	8988	900	300	600	600	600	500	1400	1700	2500	3200
	BCG 15-630	15 ~ 25												3300
	FCG 02-710	20 ~ 30												3400
	BCG 15-710	25 ~ 40												3500
1926	FCG 02-710	15 ~ 25	184.5	9912	1300	300	600	600	600	500	1500	1900	2600	3500
	BCG 15-710	20 ~ 30												3700
	FCG 05-800	25 ~ 40												3800
	BCG 15-800	25 ~ 40												3900
2127	FCG 05-710	15 ~ 25	215.3	11564	1300	300	600	600	600	500	1500	2100	2700	3700
	BCG 15-710	20 ~ 30												3800
	FCG 05-800/GI	25 ~ 40												3900
	BCG 15-800/GI	30 ~ 50												4000
2230	FCG 05-800	20 ~ 30	254.8	13688	1300	300	600	600	600	500	1700	2200	3000	4000
	BCG 15-800	20 ~ 30												4200
	FCG 05-900	30 ~ 50												4300
	BCG 15-900	40 ~ 50												4400
2234	FCG 05-800/GI	20 ~ 40	298.7	16048	1300	300	600	600	600	500	1700	2200	3400	4000
	BCG 15-800/GI	20 ~ 40												4200
	FCG 05-900/GI	30 ~ 60												4300
	BCG 15-900/GI	40 ~ 60												4400
2434	FCG 05-900	25 ~ 40	325.1	17464	1300	300	600	600	600	500	1900	2400	3400	4400
	BCG 15-900	25 ~ 40												4500
	FCG 05-1000	40 ~ 60												4600
	BCG 15-1000	40 ~ 60												4700
2636	FCG 05-900/GI	25 ~ 50	377.8	20296	1300	300	600	600	600	500	1900	2600	3600	4600
	BCG 15-900/GI	25 ~ 50												4700
	FCG 05-1000	40 ~ 75												4800
	BCG 15-1000	40 ~ 75												4900

*HH - Height Horizontal

**HV - Height Vertical

Note:

- 1) External AHU Length = (Section Length + K) mm
K = 110mm for 25mm casing thickness
160mm for 50mm casing thickness
- 2) External AHU Width = (Unit Width + K) mm
- 3) For Horizontal Unit, External AHU Height = (HH + K + 100*) mm
For Vertical Unit, External AHU Height = (HV + 2K + 100*) mm
*100mm is for unit base
- 4) If the External AHU Length is > 1900mm, section will be split into several casing for shipping purposes.

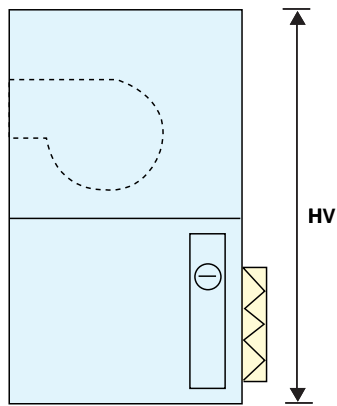
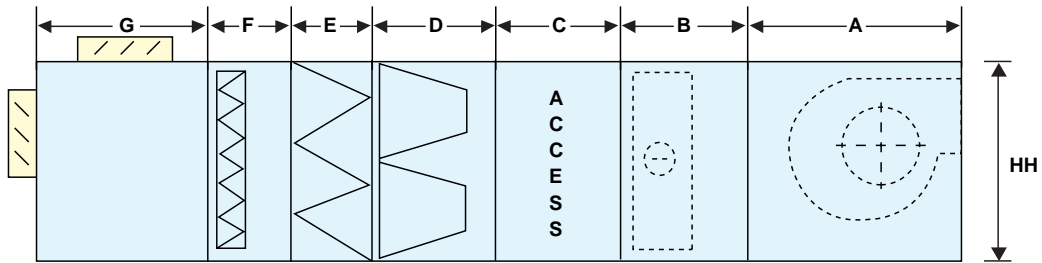

Horizontal Fan Arrangements

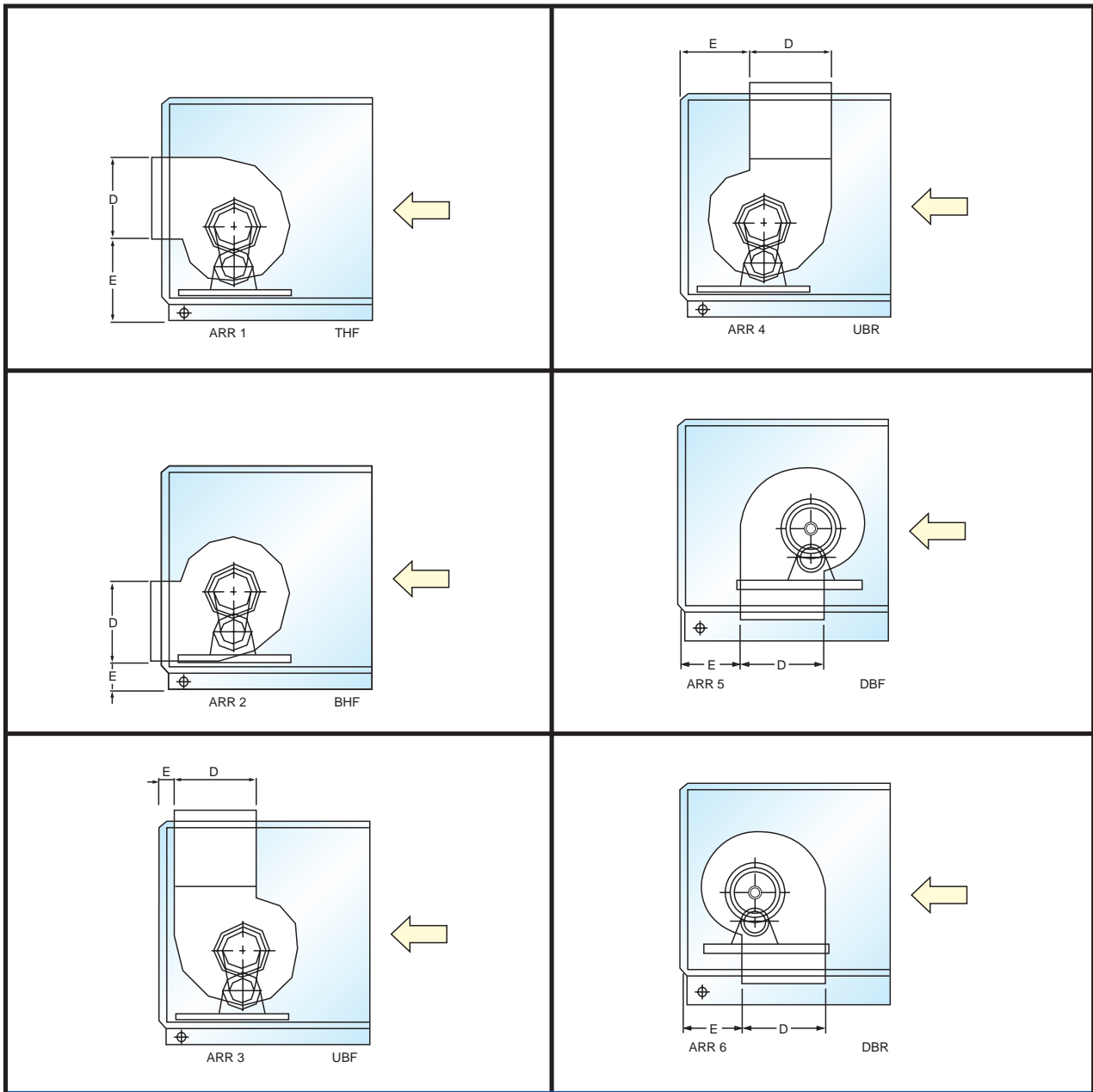

Side Elevation

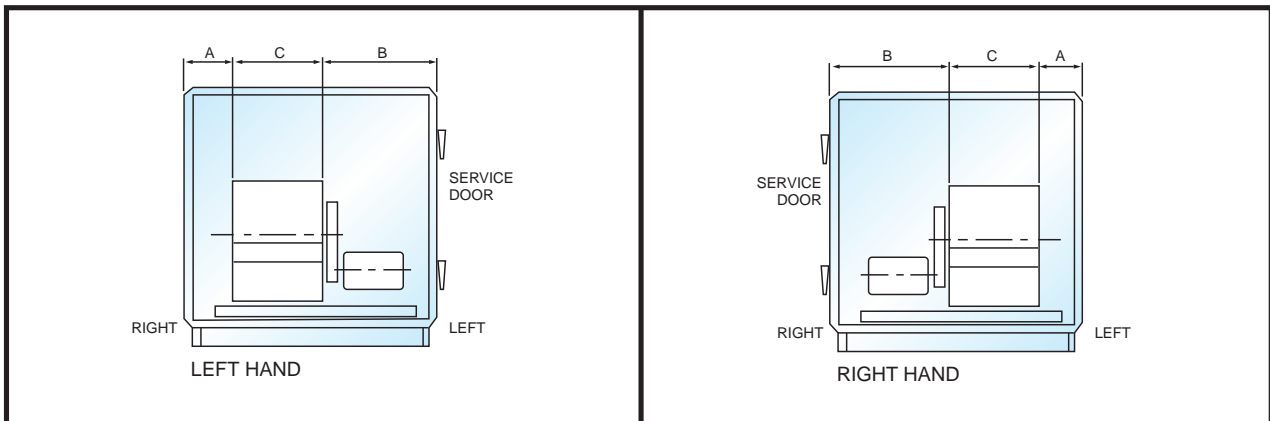

Front Elevation

Base Unit Casing Weight

Table below shows the base unit casing weight (Approximation) for 25mm, 50mm and 50mm NTB casing

Unit size	MXB (mm)		Fan (mm)		Coil (mm)		HVF (mm)		BF (mm)		LVF (mm)		ACC (mm)	
	25	50	25	50	25	50	25	50	25	50	25	50	25	50
0508A	51	61	25	30	25	30	10	12	34	40	35	41	30	36
0508B	51	61	25	30	25	30	10	12	34	40	35	41	30	36
0511	66	79	30	36	30	36	12	14	42	49	42	49	36	43
0612	70	84	40	48	33	39	13	16	46	54	54	62	40	48
0713	82	98	50	60	35	41	14	17	50	58	62	70	42	50
0813	94	113	60	72	37	45	15	18	54	64	64	74	44	54
0914	100	120	72	86	40	48	16	19	60	70	73	83	48	58
0916	110	132	78	94	43	51	17	20	65	76	78	89	52	63
1018	118	142	95	114	48	57	19	23	73	85	94	106	58	70
1118	120	144	100	120	50	59	20	24	75	87	98	110	60	72
1319	122	146	115	138	52	62	21	25	78	91	108	121	62	75
1422	131	157	151	181	56	66	22	26	82	96	117	131	65	79
1522	140	168	169	203	58	69	25	30	85	99	123	137	67	81
1722	147	176	183	220	60	71	27	32	91	103	139	151	71	83
1724	155	186	189	227	63	76	29	34	96	109	147	160	75	88
1725	167	200	201	241	66	79	31	37	100	115	159	174	77	92
1926	172	206	224	269	68	81	33	39	107	122	168	183	82	97
2127	185	222	260	312	72	90	35	41	114	129	180	195	87	102
2230	195	234	308	370	76	90	37	45	119	134	208	223	90	105
2234	215	258	342	410	80	95	39	47	126	141	222	237	95	110
2434	225	270	363	436	84	99	41	49	131	146	230	245	98	113
2636	240	288	419	503	89	106	43	51	139	154	245	260	104	119

Note: Weight in kg

Fan Motor Weight

Table below shows the approximate fan motor weight

Motor HP	Motor kW	Approx. Weight (kg)	Frame Number
1	0.75	15	D80
1.5	1.1	20	D90S
2	1.5	22	D90L
3 & 4	2.2/3.0	30	D100L
5 & 5 1/2	3.7/4.4	42	D112M
7.5	5.5	65	D132S
10	7.5	76	D132M
15	11	118	D160M
20	15	139	D160L
25	18.5	189	D180M
30	22	203	D180L
40	30	290	D200L
50	37	320	D225SC
60	45	355	D225MC
75	55	520	D2250SA

Notes :

- Motor weights based on 4 - pole 415/3Ø/50Hz induction type TEFC motor foot mounted.
- Motor shall be of Δ , Y or D.O.L. wiring.
- Standard motor shall be per IEE standard IP54 enclosure with Class F insulation and B Temperature rise complying with BS2757.
- Maximum ambient temperature 40°C.
- For derivation of motor kW from fan BkW use

$$\text{Motor kW} = \text{Fan BkW} \times A, \text{ where } A = 1.20 \text{ if BkW} < 10\text{kW}$$

$$A = 1.15 \text{ if BkW} > 10\text{kW}$$
- Please refer to your nearest Carrier representatives for special motor voltages or application.

Fan Size And RPM Limitation/BkW Limitation

Fan Type	Fan Size	Maximum RPM	Maximum BkW
Forward Curved	FCG 02-160	4700	3.1
	FCG 02-180	4200	4.5
	FCG 02-200	3800	4.5
	FCG 02-225	3400	4.5
	FCG 02-280	2700	6.2
	FCG 02-315	2400	6.2
	FCG 02-355	2100	6.2
	FCG 02-400	1900	6.2
	FCG 05-450	1700	16.0
	FCG 05-500	1500	16.0
	FCG 02-560	1200	13.0
	FCG 02-630	950	13.0
	FCG 05-630	950	26.0
	FCG 02-710	850	16.0
	FCG 05-710	850	39.1
	FCG 05-800	750	39.1
	FCG 05-800/G1	750	47.8
	FCG 05-900	670	47.8
	FCG 05-900/G1	670	47.8
	FCG 05-1000	600	6.5
Backward Curved	BCG 12-225	6640	6.5
	BCG 12-280	5300	6.5
	BCG 12-315	4730	6.5
	BCG 12-355	4200	6.5
	BCG 15-400	3600	20.0
	BCG 15-450	3360	26.6
	BCG 15-500	2050	26.6
	BCG 15-560	2400	30.0
	BCG 15-630	1880	26.0
	BCG 15-710	2000	49.9
	BCG 15-800	1470	45.0
	BCG 15-800/G1	1470	45.0
	BCG 15-900	1430	62.0
	BCG 15-900/G1	1430	62.0
	BCG 15-1000	1140	60.0

Remark : A selection is valid provided if first reaches and not exceed either max. limits (RPM of BkW).

Filter Type, Dimension And Quantity For Each AHU Size

PART NAME	PART NO.	MODEL																					
		0508A	0508B	0511	0612	0713	0813	0914	0916	1018	1118	1319	1422	1522	1722	1724	1725	1926	2127	2230	2234	2434	2636
a) HEPA Filter EU13 Particle Board Frame (Media Thickness 292mm) (H305 x W305)mm (H305 x W610)mm (H508 x W508)mm (H610 x W610)mm	-	-	1	-	-	-	-	-	-	-	-	-	-	-	-	-	-	-	-	-	-	-	-
	39GA509-320	-	-	-	-	-	-	-	-	-	-	-	-	-	-	-	-	-	-	-	-	-	-
	39GA509-321	1	1	-	-	-	-	-	-	2	-	-	-	-	3	-	-	-	-	-	-	5	-
	39GA509-322	-	-	2	2	2	2	2	2	2	6	-	-	-	12	12	12	12	9	20	24	-	-
	39GA509-323	-	-	-	-	-	-	-	2	2	2	6	-	6	6	-	-	-	-	-	-	15	20
b) 1" Bag Filter 402mm L (H289 x W391)mm (H391 x W595)mm (H289 x W595)mm (H595 x W595)mm	-	-	1	-	-	-	-	-	-	-	-	-	-	-	-	-	-	-	-	-	-	-	-
	39GA509-388	-	1	-	-	-	-	-	-	-	-	-	-	-	-	-	-	-	-	-	-	-	-
	39GA509-384	-	1	1	-	-	2	2	3	3	-	-	2	5	5	5	4	-	4	7	8	4	4
	39GA509-381	1	-	4	-	2	2	2	2	3	3	6	6	6	6	6	8	12	12	12	15	20	20
	39GA509-386	-	-	-	-	2	-	2	2	3	3	6	6	6	6	6	8	12	12	12	15	20	20
c) 1" Bag Filter 450mm L (H289 x W391)mm (H391 x W595)mm (H289 x W595)mm (H595 x W595)mm	-	-	1	-	-	-	-	-	-	-	-	-	-	-	-	-	-	-	-	-	-	-	-
	39GA509-396	-	1	-	-	-	-	-	-	-	-	-	-	-	-	-	-	-	-	-	-	-	-
	39GA509-392	-	1	-	-	2	2	3	3	3	-	-	2	5	5	5	4	-	4	7	8	4	4
	39GA509-389	1	-	4	-	2	2	2	2	3	3	6	6	6	6	6	8	12	12	12	15	20	20
	39GA509-394	-	-	-	-	2	-	2	2	3	3	6	6	6	6	8	12	12	12	12	15	20	20
d) 1" Bag Filter 529mm L (H289 x W391)mm (H391 x W595)mm (H289 x W595)mm (H595 x W595)mm	-	-	1	-	-	-	-	-	-	-	-	-	-	-	-	-	-	-	-	-	-	-	-
	39GA509-380	-	1	-	-	-	-	-	-	-	-	-	-	-	-	-	-	-	-	-	-	-	-
	39GA509-376	-	1	1	-	-	2	2	3	3	-	-	2	5	5	5	4	-	4	7	8	4	4
	39GA509-373	1	-	4	-	2	2	2	2	3	3	6	6	6	6	6	8	12	12	12	15	20	20
	39GA509-378	-	-	-	-	2	-	2	2	3	3	6	6	6	6	8	12	12	12	12	15	20	20
e) 1" HVF Filter Washable (H289 x W391)mm (H391 x W595)mm (H289 x W595)mm (H595 x W595)mm	-	-	1	-	-	-	-	-	-	-	-	-	-	-	-	-	-	-	-	-	-	-	-
	39GA509-130	-	1	-	-	-	-	-	-	-	-	-	-	-	-	-	-	-	-	-	-	-	-
	39GA509-035	-	1	1	-	-	2	2	3	3	-	-	2	5	5	5	4	-	4	7	8	4	4
	39GA509-032	1	-	4	-	2	2	2	2	3	3	6	6	6	6	6	8	12	12	12	15	20	20
	39GA509-037	-	-	-	-	2	-	2	2	3	3	6	6	6	6	8	12	12	12	12	15	20	20
f) 2" HVF Filter Washable (H289 x W391)mm (H391 x W595)mm (H289 x W595)mm (H595 x W595)mm	-	-	1	-	-	-	-	-	-	-	-	-	-	-	-	-	-	-	-	-	-	-	-
	39GA509-131	-	1	-	-	-	-	-	-	-	-	-	-	-	-	-	-	-	-	-	-	-	-
	39GA509-041	-	1	1	-	-	2	2	3	3	-	-	2	5	5	5	4	-	4	7	8	4	4
	39GA509-038	1	-	4	-	2	2	2	2	3	3	6	6	6	6	6	8	12	12	12	15	20	20
	39GA509-043	-	-	-	-	2	-	2	2	3	3	6	6	6	6	8	12	12	12	12	15	20	20
g) 1" HVF Filter Disposable (H289 x W391)mm (H391 x W595)mm (H289 x W595)mm (H595 x W595)mm	-	-	1	-	-	-	-	-	-	-	-	-	-	-	-	-	-	-	-	-	-	-	-
	39GA509-128	-	1	1	-	-	2	2	3	3	-	-	2	5	5	5	4	-	4	7	8	4	4
	39GA509-023	1	-	4	-	2	2	2	2	3	3	6	6	6	6	6	8	12	12	12	15	20	20
	39GA509-020	-	-	-	-	2	-	2	2	3	3	6	6	6	6	8	12	12	12	12	15	20	20
	39GA509-025	-	-	-	-	2	-	2	2	3	3	6	6	6	6	8	12	12	12	12	15	20	20
h) 2" HVF Filter Disposable (H289 x W391)mm (H391 x W595)mm (H289 x W595)mm (H595 x W595)mm	-	-	1	-	-	-	-	-	-	-	-	-	-	-	-	-	-	-	-	-	-	-	-
	39GA509-129	-	1	1	-	-	2	2	3	3	-	-	2	5	5	5	4	-	4	7	8	4	4
	39GA509-029	1	-	4	-	2	2	2	2	3	3	6	6	6	6	6	8	12	12	12	15	20	20
	39GA509-026	-	-	-	-	2	-	2	2	3	3	6	6	6	6	8	12	12	12	12	15	20	20
	39GA509-031	-	-	-	-	2	-	2	2	3	3	6	6	6	6	8	12	12	12	12	15	20	20

Note: Dimension in mm

Fan Housing Dimension And Weight

Table below shows full details of 39G fan housing dimension and weight.

Fan Size	Length (mm)	Width (mm)	Height (mm)	Weight (kg)
Forward Curved				
FCG 02-160	269	257	315	7
FCG 02-180	299	282	352	9
FCG 02-200	328	309	388	10
FCG 02-225	366	350	433	12
FCG 02-280	449	423	532	20
FCG 02-315	502	465	596	23
FCG 02-355	562	515	669	30
FCG 02-400	632	578	750	45
FCG 05-450	708	644	826	65
FCG 05-500	827	713	952	80
FCG 02-560	875	787	1046	97
FCG 02-630	979	874	1173	115
FCG 05-630	1028	876	1198	137
FCG 02-710	1104	971	1324	175
FCG 05-710	1152	973	1342	183
FCG 05-800	1290	1092	1509	233
FCG 05-800/G1	1290	1092	1509	233
FCG 05-900	1448	1225	1697	316
FCG 05-900/G1	1448	1225	1699	316
FCG 05-1000	1573	1362	1889	376
Backward Curved				
BCG 12-225	366	350	432	15
BCG 12-280	449	423	532	23
BCG 12-315	502	465	596	27
BCG 12-355	562	515	699	36
BCG 15-400	625	580	731	61
BCG 15-450	708	644	826	73
BCG 15-500	827	713	952	94
BCG 15-560	921	789	1074	125
BCG 15-630	1028	876	1198	149
BCG 15-710	1152	973	1342	201
BCG 15-800	1290	1092	1509	250
BCG 15-800/G1	1290	1092	1509	250
BCG 15-900	1448	1225	1697	358
BCG 15-900/G1	1448	1225	1697	358
BCG 15-1000	1573	1362	1889	416

Note: Width does not include both end of shaft.

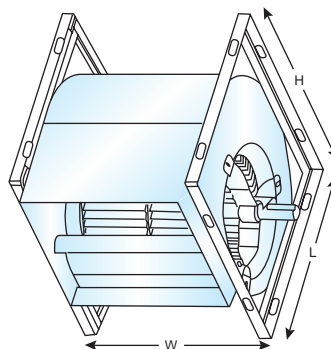

Guide Specification

General

- 1.1 Furnish and install central station air handling units of the type, size and capacity shown on the equipment schedule.
- 1.2 Equipment schedules and specifications are based on Carrier 39G 'Galaxy' series. The design of the air-handling unit is based on the use of modular panels and extruded aluminium perimeter frames with composite material for corner piece. Other manufacturers of equal quality may be submitted to the consulting engineers for approval. When substitution of equipment is made, the contractor shall be responsible for the cost of any item and engineering revision necessary to satisfy plans and specifications.
- 1.3 Units shall be horizontal or vertical draw-through type as shown on the drawings and shall consist (in the direction of air flow) a mixing box section, a filter section, a coil section and a fan section generally in accordance with the attached equipment schedules.
- 1.4 Unit shall be supplied with welded unit base with holes for rigging located to suit optimum hoisting stability. The use of slings and spreader bars are recommended for large section.

Casing Construction (25mm and 50mm)

- 2.1 The unit casing construction shall have double skin construction to allow access without damaging the insulation and isolating it from the air stream.
- 2.2 The casing shall have extruded aluminium perimeter frame, with modular panels and composite material corner piece. The panels shall be constructed such that they shall comprise of two layers of steel sheet with injected insitu CFC-Free Polyurethane insulation with thermal conductivity factor of 0.019 w/mk and density of 40kg/m³ in between. The assembly of six panels to the perimeter frame shall be from inside the unit. The removable panels should be provided on the both sides of the units with hex socket compression type latch assembly and large & non-conductive handles. All external panels surface shall be pre-painted zinc allume. Internal panels shall be galvanised steel sheet.

Fan Section

- 3.1 The fan shall be of the forward curved or backward curved DIDW centrifugal type. The blade of forward curved wheels shall be galvanised steel. The blade of backward curved wheel shall be heavy gauge steel, treated and painted after manufacture. The fan assembly shall be statically and dynamically balanced to the 80% of maximum fan speed as shown in the schedule.
- 3.2 Factory/field furnished and installed fan motors shall be mounted inside the fan section on the mounting base. The motors shall be of the totally enclosed fan cooled (TEFC) type (or open drip proof type) suitable for use with...Volts...Phase....Hz electrical supply. Motor speed shall be as per schedule.

- 3.3 The fan drive package shall consist of foxed pitch fan and motor pulleys and V-belts, adequately sized to accommodate the application service factor.
- 3.4 The fan and motor assembly shall be mounted on an adjustable mounting base with factory supplied spring anti-vibration mountings or rubber isolator. The fan discharge shall be square (for forward curved or backward curved fans) in area and flanged and isolated from the casing by a fire retardant grade flexible connection. Only on fan discharge shall be provided.

Coil

- 4.1 The coils shall be of the cartridge type, mounted over the condensate drain pan (for cooling coil). Coils shall be tested at 2760kPag air pressure while submerged in water. Coils performance shall be rated in accordance to ARI standard 410.
- 4.2 Chilled Water coils shall have aluminium/copper fins with belled collars and bonded to 12.7mm OD copper tubes by mechanical expansion. Fins shall be of the "Dual Sinewave" form. Coil shall have galvanised steel casing and steel headers with male threaded connections. Working pressure shall be 2060kPag at 93°C. Coils shall be drainable and have non-air-trapping circuits. No turbulence promoting devices will be permitted inside the tubes. Headers shall have drain and vent connections. Note : copper header shall be sweat type connection (braze).
- 4.3 Direct expansion coil shall have aluminium/copper fins with belled collars and bonded to 12.7mm OD copper tubes by mechanical expansion. Fins shall be of the "Dual Sinewave" form. Coils shall be provided with brass distributors with sweat type connections. Coils shall have full-face active area with intertwined circuits for equal loading on each circuit. Suction and metering valve connection shall be on the same end. After leak testing, coil shall be charged with dry air. Coils shall be designed and tested in accordance to ARI standard.
- 4.4 Hot Water coils shall be constructed similar to the chilled water coil as per Section 4.3 except that the maximum working pressure shall be 1200kpag at 205°C.
- 4.5 All coils shall have counter flow arrangement.
- 4.6 The condensate drain pan shall be constructed by 16-gauge powder painted Galvanised Steel with 40mm depth and 400mm in length. Slider shall be welded at drain pan for easier coil installation and removal. The condensate drain pan shall be constructed in slope with one female threaded pipe connection of 43mm OD routed through bottom for drainage in accordance to ASHRAE 62-89 Standard.

Guide Specification

Filter Section

- 5.1 The filter section shall be supplied by the air handling unit manufacturer with the same casing construction as specified for the other unit sections. The type of filters to be housed within the filter section shall be the type and efficiency indicated on the equipment schedule.
- 5.2 High velocity filter section shall be capable of receiving 25mm or 50mm thick filters of standard size. Low velocity filter section shall be capable of receiving 50mm deep filters mounted in 50mm width holding frames.
- 5.3 Bag filter section shall be capable of accepting bag filters with length up to 596mm and 22mm-filter header thickness.

Mixing Box

- 6.1 Mixing boxes shall be parallel bladed, interconnected outside air and return air dampers. Damper blades shall be brake formed for stiffness and shall be mechanically secured to 13mm OD steel rods rotating in nylon bushings and mounted in rigid powder painted steel damper frames. Dampers shall be sectionalised to limit blade length to not more than 1480mm in order to prevent excessive blade warping and ensure tight closure.

Access Section

- 7.1 Access section shall be supplied by the air handling unit manufacturer with the same casing construction as specified for the other sections. The access panels shall be ultra low leak construction with hex socket compression type latch assembly and large & non-conductive handles for easy removal of the access panel. The access panel shall be double skinned construction and internally insulated with injected insitu CFC-Free polyurethane insulation. The access panel perimeter shall be lined with ribseals.

ViewPorts

- 8.1 Viewports shall be available as factory installed option on access doors. The viewports shall be fabricated from round, double plane, clear and rigid polycarbonate with a minimum diameter of 200.0mm and installed with screws that do not come into direct contact with the internal surface of the air handling unit. The viewport shall be gasketed on the internal and external surfaces with thermoplastic elastomer (TPE) gaskets to ensure air-tightness. The viewport shall be capable of withstanding unit operating pressures.

Marine Lamp

- 9.1 Marine lamps shall be available as factory-installed option on the fan and access sections of the air handling unit. The construction shall be vapour and weather tight rated to IP44. The marine lamp shall consist of a structural light fitting base with aluminium reflector and receptacle, and a structural glass globe protected by wire mesh. The marine lamp shall come fitted with a light bulb complete with factory installed wiring and conduits and terminated with an on/off switch located external to the unit and near to the access door.

Drain Pan

- 10.1 The drain pan shall be available fabricated in galvanized steel and powder painted to withstand ASTM B-117 Salt Spray Test at 500 hours. The drain pan shall have option of being fabricated in Stainless Steel SUS 304.
- 10.2 The drain pan shall be constructed to have full width, single sloped drain pan to ensure positive condensate drainage and shall extend downstream of the coil to provide sufficient amount of space to contain moisture carry-over. The coil shall not sit in the drain pan and shall be removable via coil tracks. The drain pan shall have an integral FPT elbow for side discharge and trapping.
- 10.3 The drain pan must be accessible for inspection and cleaning.



Carrier International Sdn. Bhd. (3385-T)
Lot 4, Jalan P/6, 43650 Bandar Baru Bangi,
Selangor, Malaysia.
Tel: 03-8925 8001
Fax: 03-8925 3578

39G	Rev. 3
05	2003