

**50EES--ZP (50Hz)
Single Package
Air Conditioners
3 - 5 Nominal Tons**



Turn to the Experts.™

Product Data

The 50EES unit with ZP technology is a package air conditioner for manufactured housing, residential, and light commercial applications. The 50EES unit design is the result of our firm commitment to the development of the finest air conditioners that modern technology can offer. The 50EES unit is built in one basic cabinet size and features rectangular duct configuration on sizes 035-060.

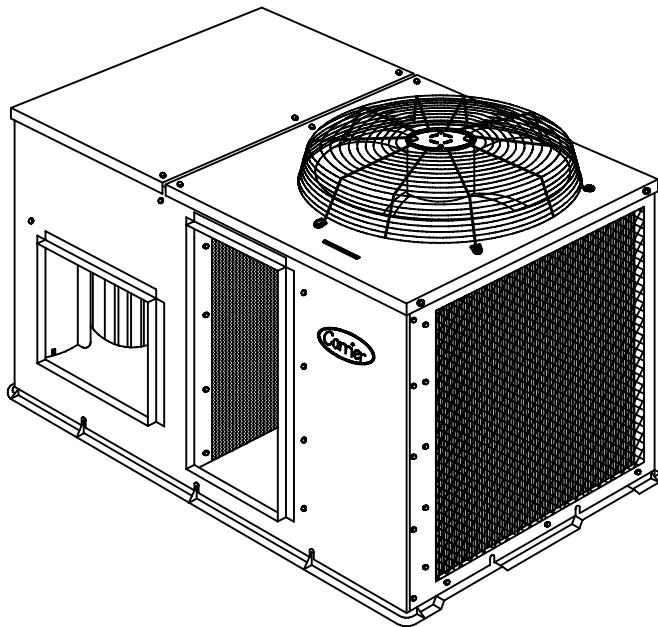

Features/Benefits

FACTORY-ASSEMBLED PACKAGE is a compact, fully self-contained, electric cooling unit with horizontal supply and return ducts. The 50EES units are available in a variety of standard cooling sizes with voltage options to meet residential and light commercial requirements. Unit installs easily on a ground level pad.

EASY TO INSTALL

50EES units are small, compact, and easy to handle. Every 50EES unit has an identical 32 x 51-in. footprint to make planning simple. The concise design uses less sheet metal and makes the 50EES units lighter than other units. The unit can be easily positioned on the jobsite with the hand holds built into the unit basepan. Drop-in cartridge style heaters are utilized to minimize installation time. The 50EES unit was designed with potential safety hazards in mind; with no sharp edges or corners which could injure a worker.

NEW IMPROVED AERODYNAMIC FAN BLADE DESIGN reduces the overall sound by up to 6dB; now as low as 78dB.

TOP COVER SERVICE ACCESS

Makes installation and maintenance quicker and easier. The 50EES units are designed to be serviced from the top. The split-top design allows easy access for installation and maintenance procedures of the unit. Routine maintenance tasks such as coil cleaning are sped up with through-the-top access. Multiple side panels do not need to be removed as with other units.

NO-RUST BASEPAN WITH INTEGRATED DRAIN PAN

Is standard on all units. The 50EES units feature a tough hightech, composite material basepan with integrated drain pan. The composite material eliminates the potential problems of rust and premature replacement which are common with standard metal basepans. Durable oven backed polyester powder painted galvanized steel) protects against harsh weather.



The watertight construction and corrosion-resistant finish of the 50EES unit will keep it looking like new for years. The paint treatment process ensures quality protection against the elements. A compact, low-profile design utilizes an expanded metal coil grill to make coil cleaning easy.

INDOOR AIR QUALITY is designed into the 50EES units. A sloped drain pan minimizes the amount of standing water inside the unit, which limits mold and mildew growth. The drain pan is made of a rust-proof material and will not deteriorate or release foreign matter into the airstream.

LIGHTWEIGHT, COMPACT CONSTRUCTION is ideal for manufactured housing and residential applications. The 50EES unit is one of the lightest, most compact packaged units ever designed. It's light weight (250 lbs for the 50EES 035 unit) makes the unit easier to handle. The low height keeps ductwork connections to a minimum and makes units less visible.

The 50EES units utilize a structural beam design to form the four sides of the cabinet. Only 12 different pieces of sheet metal are used in the unit construction to simplify the unit for greater reliability.

EFFICIENT, DEPENDABLE PERFORMANCE with durable compressors designed for efficiency. The 50EES units offer 9.5 SEER (Seasonal Energy Efficiency Ratio) cooling performance efficiencies. This

performance level can reduce cooling expenses by as much as 25% compared to older cooling equipment. A high-efficiency, multi-speed blower motor system ensures quality performance with most duct systems. The computer-designed blower wheel is balanced for quiet operation.

DURABLE, DEPENDABLE, COMPRESSORS are designed for high efficiency. Each compressor is hermetically sealed against contamination to help promote longer life and dependable operation. Vibration isolation provides quiet operation. Compressors have internal high-pressure and overcurrent protection.

DIRECT-DRIVE MULTISPEED, PSC (PERMANENT SPLIT CAPACITOR) BLOWER MOTOR is standard on all models. Direct-drive, PSC condenser-fan motors are designed to help reduce energy consumption and provide for cooling operation down to 40 F.

REFRIGERANT SYSTEM is designed to provide dependability. Liquid refrigerant strainers are used to promote clean, unrestricted operation. Each unit leaves the factory with a full refrigerant charge. Refrigerant service connections make checking operating pressures easier.

FIELD-INSTALLED ACCESSORY DESCRIPTION AND USAGE

Electric Heater — Heater module slides into keyed mounting slots in the fan inlet. Heater

sizes range from 5.0 to 20.0 kW. Design allows for single-point supply for entire unit. Heaters provide heating capability when required.

Corporate Thermostat — These provide cooling control for unit. Autochangeover and manual changeover types are available.

The MotorMaster II Low Ambient Kit — Kit permits operation down to 0° F. Use when mechanical cooling is required when outdoor-air temperature is between 40°F and 0°F.

Crankcase Heater — Warms crankcase oil to reduce refrigerant migration and ensure proper compressor lubrication.

Solid-State Time Guard® Device — Package consists of a control to be field-wired into the unit controls, and provides a 5-minute delay in compressor operation between cooling cycles. Prevents compressor short cycling when rapid compressor cycles may be a problem.

Controls Upgrade Kit — Contains high- and low-pressure switches to protect the unit from running at unsuitable pressures. Provides additional safety features when needed.

Outdoor Thermostat — Accessory provides control when outdoor-air temperature falls below set point. Helps to bring second stage of 2-stage electric heater on line.

ARI* capacity ratings

UNIT 50EES-ZP	NET COOLING CAPACITY†	STANDARD CFM	SEER**	SOUND RATINGS†† (dB)
035	34,200	1200	9.5	78
040	40,000	1400	9.5	78
050	46,000	1600	9.5	78
060	57,000	2000	9.5	80



LEGEND

- db — Dry Bulb
- dB — decibels
- SEER — Seasonal Energy Efficiency Ratio
- wb — Wet Bulb

* Air Conditioning & Refrigeration Institute.
 † Rated in accordance with U.S. Government DOE Department of Energy) test procedures and/or ARI Standard 210/240-89.

** All units have factory-installed time-delay relay.
 †† Rated in accordance with ARI Standard 270-84.

NOTES:

1. Ratings are net values, reflecting the effects of circulating fan heat.
2. Cooling capacity ratings are based on cooling standard: 80°F db/67°F wb indoor air entering temperature 95°F db air entering outdoor unit

Table of contents

	Page
Features/Benefits	1
ARI Capacity Ratings	2
Model Nomenclature	3
Physical Data	3
Dimensional Drawings	4-7
Selection Procedure	8
Performance Data	9-12
Typical Wiring Schematics	13
Electrical Data	14, 15
Operating Sequence	16
Typical Installation	16
Application Data	17
Engineers' Specification Guide	18

MODEL NUMBER NOMENCLATURE

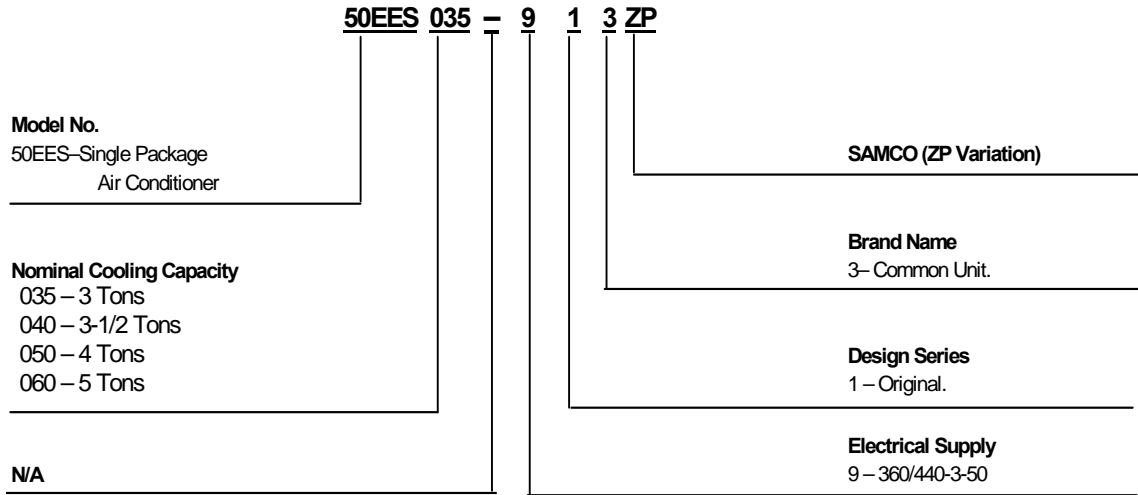

50EES-ZP

Physical data

UNIT SIZE 50EES -ZP	035	040	050	060
OPERATING WEIGHT (lb)	250	297	310	368
COMPRESSOR TYPE	Reciprocating			
REFRIGERANT	R – 22			
CHARGE (lb)	4.2	5.0	6.1	8.1
REFRIGERANT METERING DEVICE	Acutrol™ System			
CONDENSER COIL Rows – Fins/in. Total Face Area (sq ft)	Copper Tubes, Aluminum Plate Fins			
	2 – 17 6.2	1 – 17 11.1	2 – 17 8.6	2 – 17 10.7
CONDENSER MOTOR FAN	Propeller			
Condenser Cfm	2200	2800	2800	3000
Nominal Rpm	1100	1100	1100	1100
Motor Hp (Rpm)	1/4	1/4	1/4	1/4
Diameter (in.)	20	20	20	20
EVAPORATOR COIL	Copper Tubes, Aluminum Plate Fins			
Rows – Fins/in.	3 – 15	3 – 15	3 – 15	4 – 15
Total Face Area (sq ft)	3.1	3.9	4.3	4.9
EVAPORATOR – FAN MOTOR	Direct Drive			
Blower Motor Size (in.)	10 X 8	10 X 9	10 X 9	10 X 10
Nominal Cfm	1200	1400	1600	2300
Rpm Range	800 – 1050	800 – 1050	100 – 1100	950 – 1100
Number of Speeds Factory Speed	3	3	2	2
Setting	Low	Med	Low	Low
Motor Hp	1/2	1/2	3/4	1
CONNECTING DUCT SIZES	Square			
Supply Air (in.)	13.9 x 13.9			13.9 x 19
Return Air (in.)	13.9 x 13.9			13.9 x 32
FIELD-SUPPLIED RETURN AIR FILTER* Throwaway	24 x 24 x 1	24 x 24 x 1	24 x 30 x 1	24 x 30 x 1

* Required filter sizes shown are based on the ARI (Air Conditioning & Refrigeration Institute) rated airflow at a velocity of 300 ft/minute for throwaway type or 450 ft/minute for high-capacity type. Recommended filters are 1-in. thick.

Dimensional drawings — 50EES 035 – ZP

DIMENSIONS ARE IN mm. [] ARE IN INCHES

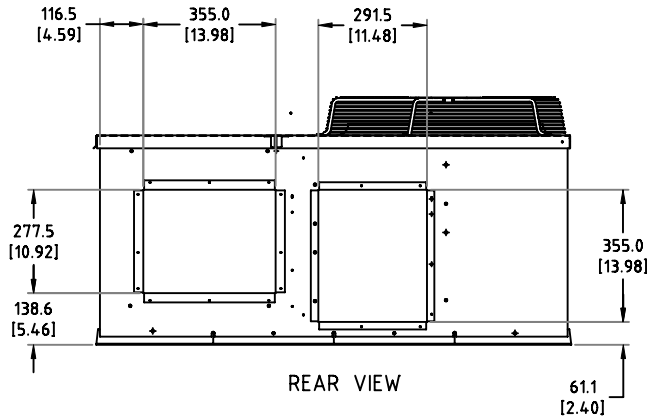

REQUIRED CLEARANCE TO COMBUSTIBLE MAT'L.

	INCHES (mm)
TOP OF UNIT	0
DUCT SIDE OF UNIT	0
SIDE OPPOSITE DUCTS	0
BOTTOM OF UNIT	0

NEC. REQUIRED CLEARANCES.

	INCHES (mm)
BETWEEN UNITS, POWER ENTRY SIDE	42.00 [1066.8]
UNIT AND UNGROUNDED SURFACES, POWER ENTRY SIDE ...	36.00 [914.0]
UNIT AND BLOCK OR CONCRETE WALLS AND OTHER	
GROUNDED SURACES, POWER ENTRY SIDE	42.00 [1066.8]

REQUIRED CLEARANCE FOR OPERATION AND SERVICING.

	INCHES (mm)
CONDENSER COIL ACCESS SIDE	30.00 [762.0]
POWER ENTRY SIDE	30.00 [762.0]
(EXCEPT FOR NEC REQUIREMENTS)	
UNIT TOP	48.00 [1219.2]
SIDE OPPOSITE DUCTS	30.00 [762.0]

LEGEND

NEC - National Electric Code

NOTES:

- Clearances must be maintained to prevent recirculation of air from outdoor-fan discharge, with the exception of the condenser coil (36.00 in [914.0 mm]. A removable fence or barricade requires no clearance.
- Dimensions are in inches. Dimensions in [] are in millimeters.

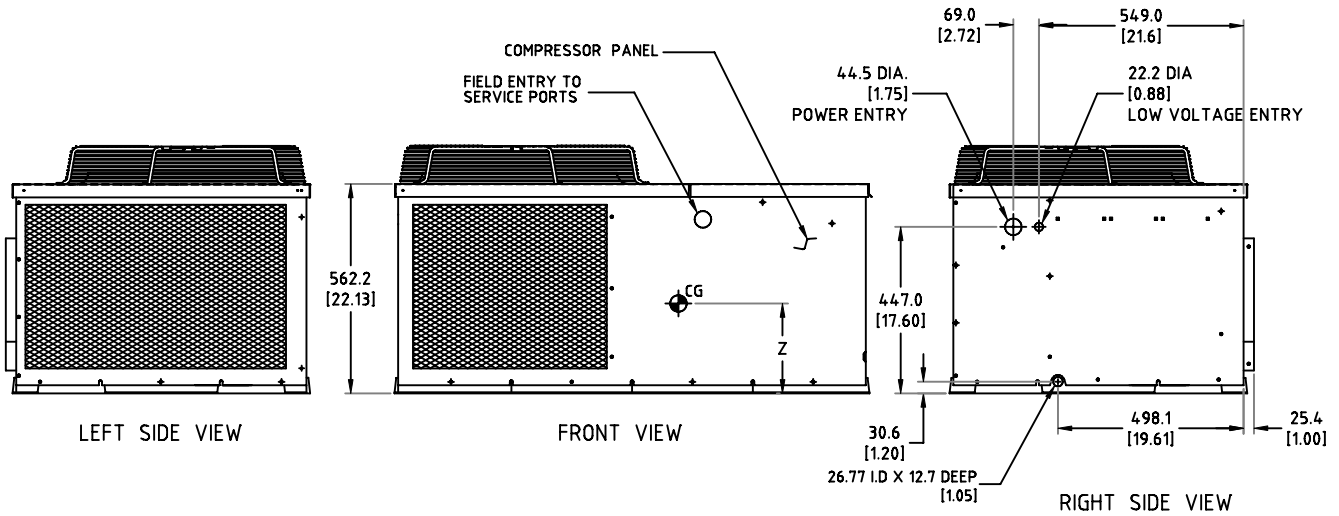
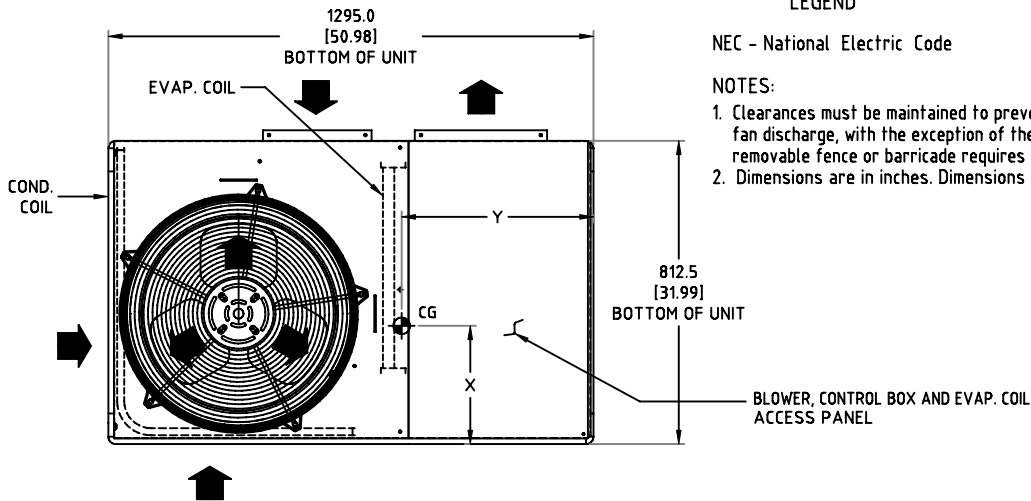

UNIT 50EES-ZP	ELECTRICAL CHARACTERISTICS	UNIT WEIGHT		CENTER OF GRAVITY in. [mm]		
		lb.	kg.	X	Y	Z
035	400V / 3PH / 50HZ	250	114	355.6 (14.00)	508.0 (20.00)	24.13 (9.50)

Dimensional drawings — 50EES 040 – ZP

DIMENSIONS ARE IN mm. [] ARE IN INCHES

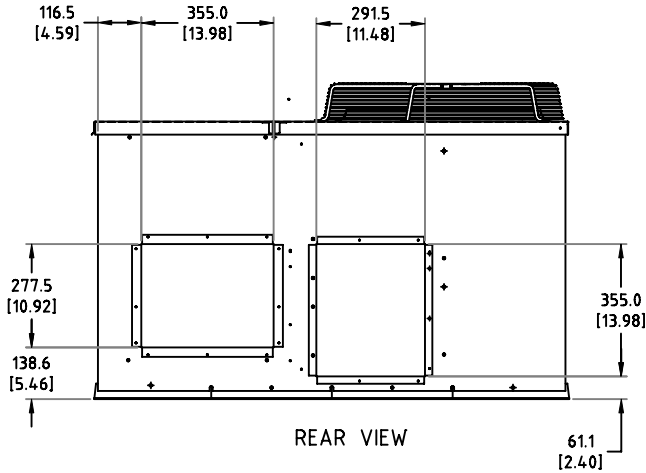

REQUIRED CLEARANCE TO COMBUSTIBLE MAT'L.

	INCHES (mm)
TOP OF UNIT	0
DUCT SIDE OF UNIT	0
SIDE OPPOSITE DUCTS	0
BOTTOM OF UNIT	0

NEC. REQUIRED CLEARANCES.

	INCHES (mm)
BETWEEN UNITS, POWER ENTRY SIDE	42.00 [1066.8]
UNIT AND UNGROUNDED SURFACES, POWER ENTRY SIDE ...	36.00 [914.0]
UNIT AND BLOCK OR CONCRETE WALLS AND OTHER GROUNDED SURACES, POWER ENTRY SIDE	42.00 [1066.8]

REQUIRED CLEARANCE FOR OPERATION AND SERVICING.

	INCHES (mm)
CONDENSER COIL ACCESS SIDE	30.00 [762.0]
POWER ENTRY SIDE	30.00 [762.0]
(EXCEPT FOR NEC REQUIREMENTS)	
UNIT TOP	48.00 [1219.2]
SIDE OPPOSITE DUCTS	30.00 [762.0]

LEGEND

NEC - National Electric Code

NOTES:

- Clearances must be maintained to prevent recirculation of air from outdoor-fan discharge, with the exception of the condenser coil (36.00 in [914.0 mm]). A removable fence or barricade requires no clearance.
- Dimensions are in inches. Dimensions in [] are in millimeters.

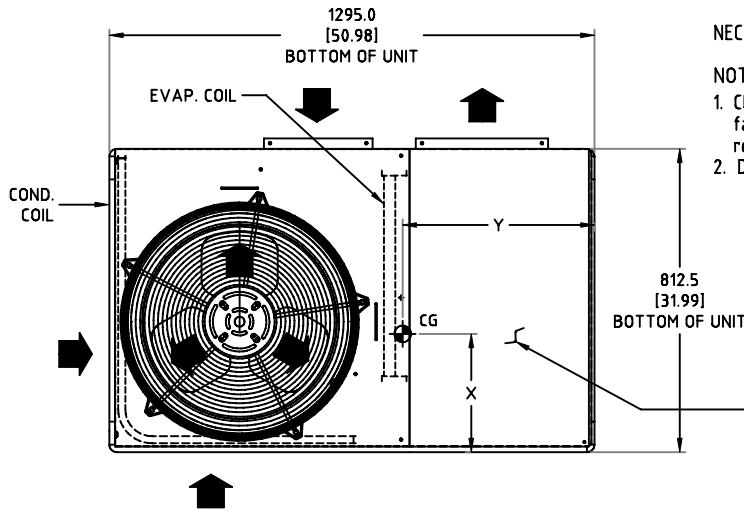

BLOWER, CONTROL BOX AND EVAP. COIL ACCESS PANEL

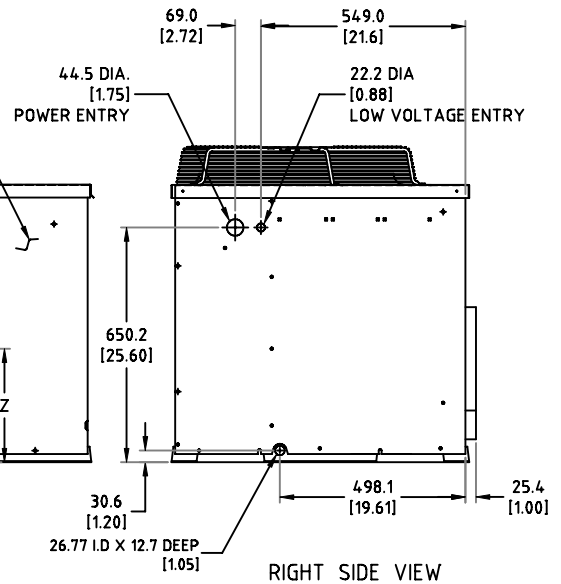
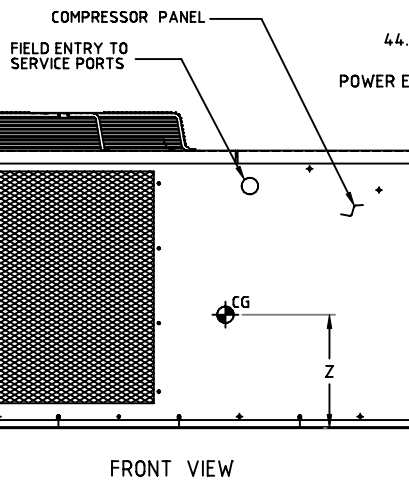
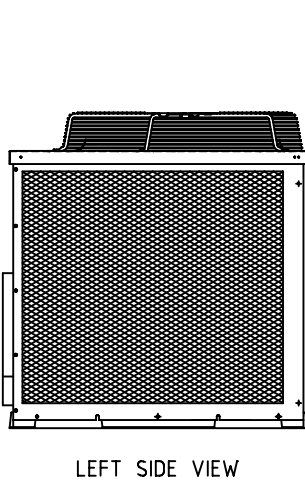

UNIT 50EES-ZP	ELECTRICAL CHARACTERISTICS	UNIT WEIGHT		CENTER OF GRAVITY in. [mm]		
		lb.	kg.	X	Y	Z
040	400V / 3PH / 50HZ	297	135	355.6 (14.00)	508.0 (20.00)	304.8 (12.00)

50EES-ZP

Dimensional drawings — 50EES 050 – ZP

DIMENSIONS ARE IN mm. [] ARE IN INCHES

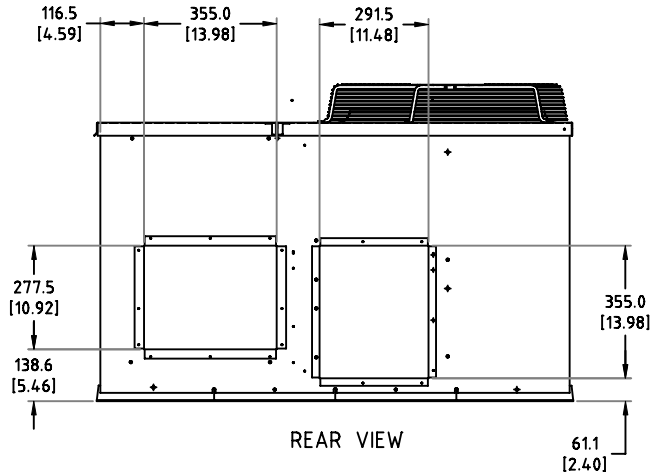

REQUIRED CLEARANCE TO COMBUSTIBLE MAT'L.

	INCHES (mm)
TOP OF UNIT	0
DUCT SIDE OF UNIT	0
SIDE OPPOSITE DUCTS	0
BOTTOM OF UNIT	0

NEC. REQUIRED CLEARANCES.

	INCHES (mm)
BETWEEN UNITS, POWER ENTRY SIDE	42.00 [1066.8]
UNIT AND UNGROUNDED SURFACES, POWER ENTRY SIDE ...	36.00 [914.0]
UNIT AND BLOCK OR CONCRETE WALLS AND OTHER	
GROUNDING SURFACES, POWER ENTRY SIDE	42.00 [1066.8]

REQUIRED CLEARANCE FOR OPERATION AND SERVICING.

	INCHES (mm)
CONDENSER COIL ACCESS SIDE	30.00 [762.0]
POWER ENTRY SIDE	30.00 [762.0]
(EXCEPT FOR NEC REQUIREMENTS)	
UNIT TOP	48.00 [1219.2]
SIDE OPPOSITE DUCTS	30.00 [762.0]

LEGEND

NEC - National Electric Code

NOTES:

- Clearances must be maintained to prevent recirculation of air from outdoor-fan discharge, with the exception of the condenser coil (36.00 in [914.0 mm]). A removable fence or barricade requires no clearance.
- Dimensions are in inches. Dimensions in [] are in millimeters.

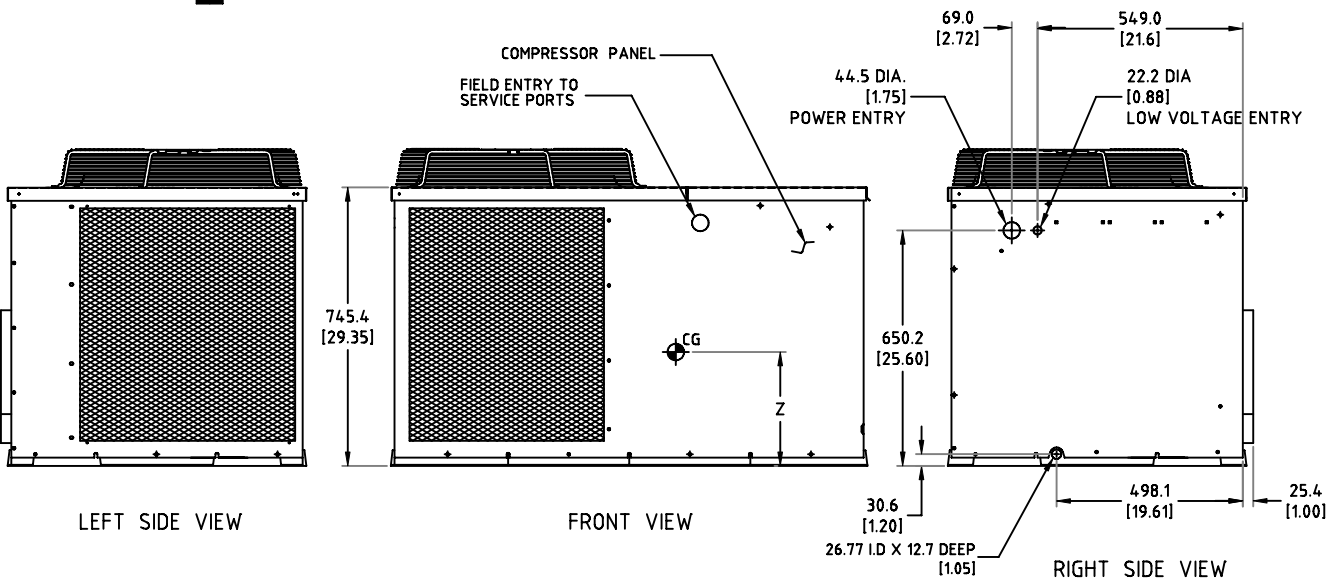
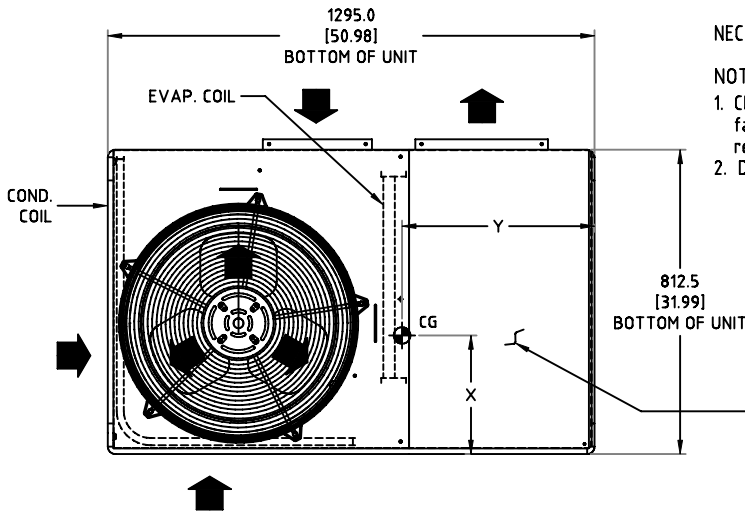

UNIT 50EES-ZP	ELECTRICAL CHARACTERISTICS	UNIT WEIGHT		CENTER OF GRAVITY in. [mm]		
		lb.	kg.	X	Y	Z
050	400V / 3PH / 50HZ	310	141	355.6 (14.00)	508.0 (20.00)	304.8 (12.00)

Dimensional drawings — 50EES 060 – ZP

DIMENSIONS ARE IN mm. [] ARE IN INCHES

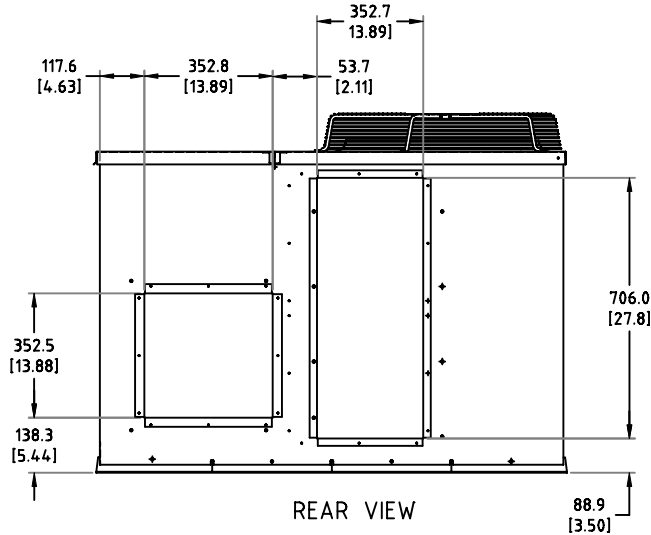

REQUIRED CLEARANCE TO COMBUSTIBLE MAT'L.

	INCHES (mm)
TOP OF UNIT	0
DUCT SIDE OF UNIT	0
SIDE OPPOSITE DUCTS	0
BOTTOM OF UNIT	0

NEC. REQUIRED CLEARANCES.

	INCHES (mm)
BETWEEN UNITS, POWER ENTRY SIDE	42.00 [1066.8]
UNIT AND UNGROUNDED SURFACES, POWER ENTRY SIDE ...	36.00 [914.0]
UNIT AND BLOCK OR CONCRETE WALLS AND OTHER GROUNDED SURFACES, POWER ENTRY SIDE	42.00 [1066.8]

REQUIRED CLEARANCE FOR OPERATION AND SERVICING.

	INCHES (mm)
CONDENSER COIL ACCESS SIDE	30.00 [762.0]
POWER ENTRY SIDE	30.00 [762.0]
(EXCEPT FOR NEC REQUIREMENTS)	
UNIT TOP	48.00 [1219.2]
SIDE OPPOSITE DUCTS	30.00 [762.0]

LEGEND

NEC - National Electric Code

NOTES:

- Clearances must be maintained to prevent recirculation of air from outdoor-fan discharge, with the exception of the condenser coil (36.00 in [914.0 mm]). A removable fence or barricade requires no clearance.
- Dimensions are in inches. Dimensions in [] are in millimeters.

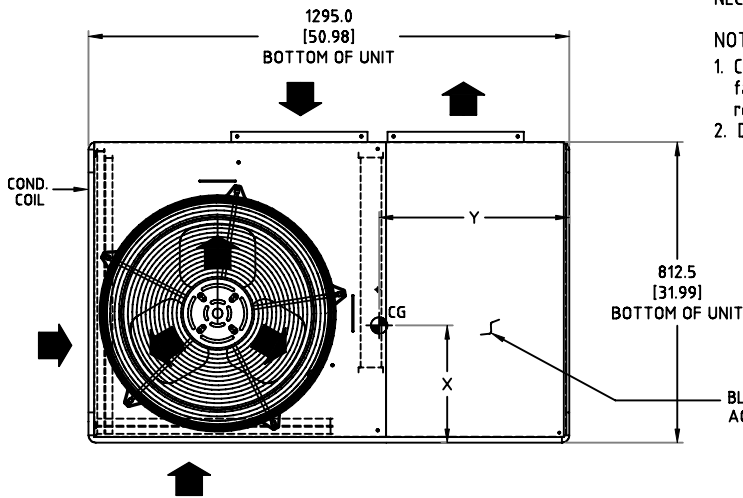

BLOWER, CONTROL BOX AND EVAP. COIL ACCESS PANEL

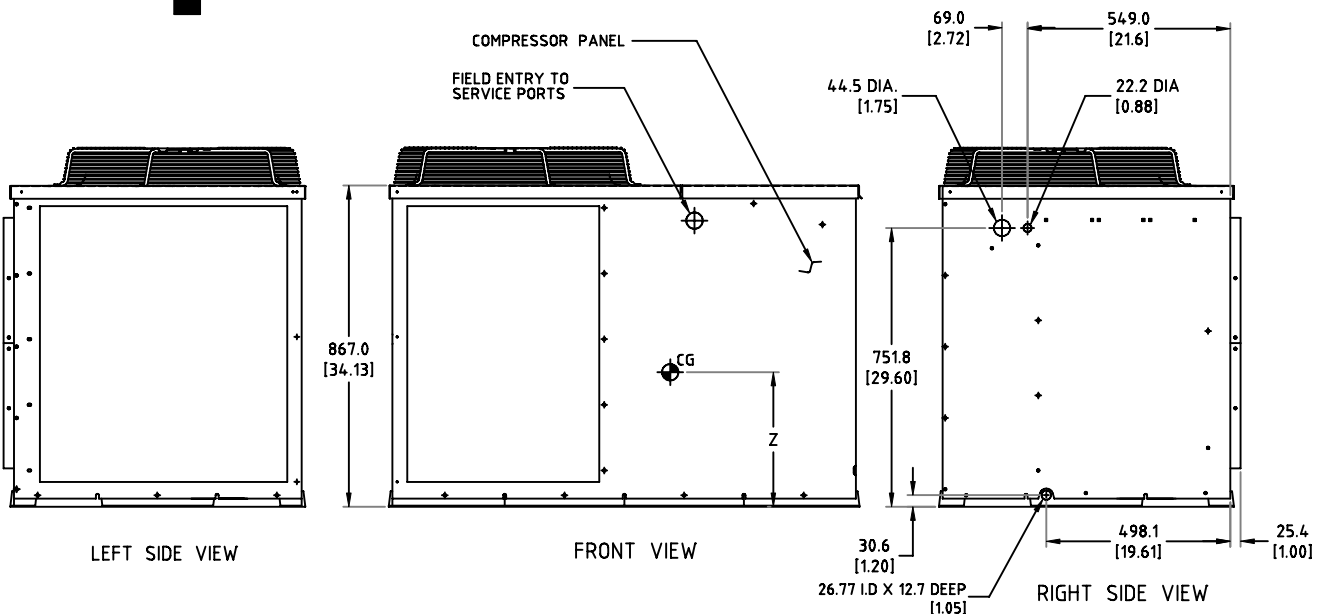

UNIT 50EES-ZP	ELECTRICAL CHARACTERISTICS	UNIT WEIGHT		CENTER OF GRAVITY in. [mm]		
		lb.	kg.	X	Y	Z
060	400V / 3PH / 50HZ	350	159	355.6 (14.00)	508.0 (20.00)	355.6 (14.00)

50EES-ZP

Selection Procedure

I DETERMINE COOLING AND HEATING REQUIREMENTS AT DESIGN CONDITIONS.

Given:

- Required Cooling Capacity (TC)34,000 Btuh
- Sensible Heat Capacity (SHC)25,000 Btuh
- Required Heating Capacity.15,000 Btuh
- Outdoor Entering-Air Temperature95°F
- Indoor Entering-Air Temperature.80°F edb; 67°F ewb
- Indoor-Air Quantity1200 cfm
- External Static Pressure0.20 in. wg
- Electrical Characteristics (V-Ph-Hz) 400-3-50

II SELECT UNIT BASED ON REQUIRED COOLING CAPACITY.

Enter Cooling Capacities table at condenser entering temperature of 95°F, indoor air entering at 1200 cfm and 67°F ewb. The 50EES035 unit provides a total cooling capacity of 34,200 Btuh and a sensible heat capacity of 25,300 Btuh.

For indoor-air temperature other than 80°F edb, calculate sensible heat capacity correction, as required, using the formula found in Note 3 following the Cooling Capacities tables.

NOTE: Unit ratings are net capacities.

III SELECT ELECTRIC HEAT.

The required heating capacity is 15,000 Btuh (given). Determine the electric heat capacity in kW.

$$\frac{15,000 \text{ Btuh}}{3414 \text{ Btuh/kW}} = 3.8 \text{ kW of heat required}$$

Enter the Accessory Electric Heater table on page 18 400 v. 3ph. 50EES 035 unit. The 5-kW heater at 400v most closely satisfies the heating required to calculate kW at 400 V, multiply the heater kW by multiplication factor 0.75 found in the Multiplication Factors table on page 18.

$$5 \text{ kW} \times 0.75 = 3.75 \text{ kW}$$

$$3.75 \text{ kW} \times 3414 \text{ Btuh/kW} = 12,803 \text{ Btuh}$$

IV DETERMINE FAN SPEED AND POWER REQUIREMENTS AT DESIGN CONDITIONS.

Before entering the air delivery tables, calculate the total static pressure required. From the given, Filter Pressure Drop table, the Accessory Electric Heat Pressure Drop table, and the Wet Coil Pressure Drop table, find:

External static pressure	0.20 in. wg
Filter	0.10 in. wg
Electric Heat	0.13 in. wg
Wet Coil	0.09 in. wg
Total static pressure	<u>0.52 in. wg</u>

Enter the table for Dry Coil Air Delivery — Horizontal Discharge. At 0.5 in. wg external static pressure and high speed, the motor delivers 1297 cfm. Interpolating for 0.52 in. wg delivers 1276 cfm, which satisfies the job requirements.

Cooling capacities

50EES 035 ZP														
EVAPORATOR AIR			CONDENSER AIR TEMPERATURE (F)											
			85			95			105			115		
Cfm	BF	F Ewb	Capacity MBtuh		Compressor kW	Capacity MBtuh		Compressor kW	Capacity MBtuh		Compressor kW	Capacity MBtuh		Compressor kW
			Total	Sensible		Total	Sensible		Total	Sensible		Total	Sensible	
1050	0.08	72	38.8	18.9	3.65	36.9	18.2	3.83	34.9	17.6	4.02	32.8	17.0	4.20
		67	35.7	24.5	3.53	33.7	23.8	3.71	31.7	23.0	3.88	29.7	22.4	4.05
		62	32.3	29.6	3.42	30.5	28.7	3.59	28.6	27.7	3.75	26.8	26.7	3.91
1200	0.10	72	39.6	19.7	3.74	37.5	19.1	3.92	35.5	18.6	4.11	33.0	17.7	4.27
		67	36.2	26.0	3.61	34.2	25.3	3.79	32.1	24.5	3.96	30.1	23.8	4.14
		62	33.0	31.5	3.15	31.1	30.5	3.67	29.3	29.3	3.84	27.7	27.7	4.03
1350	0.11	72	39.7	20.3	3.80	37.8	19.9	3.99	35.6	19.1	4.17	33.4	18.5	4.36
		67	36.8	27.6	3.70	34.6	26.7	3.87	32.5	25.9	4.03	30.4	25.2	4.21
		62	33.5	33.2	3.59	31.8	31.8	3.76	30.2	30.2	3.94	28.5	28.5	4.13

50EES 040 ZP														
EVAPORATOR AIR			CONDENSER AIR TEMPERATURE (F)											
			85			95			105			115		
Cfm	BF	F Ewb	Capacity MBtuh		Compressor kW	Capacity MBtuh		Compressor kW	Capacity MBtuh		Compressor kW	Capacity MBtuh		Compressor kW
			Total	Sensible		Total	Sensible		Total	Sensible		Total	Sensible	
1225	0.11	72	46.2	22.1	4.19	43.7	21.2	4.39	41.1	20.3	4.60	38.4	19.4	4.81
		67	39.0	25.6	3.89	38.4	26.1	4.17	36.5	25.7	4.40	34.2	25.1	4.62
		62	36.3	31.8	3.81	34.7	31.5	4.03	32.8	30.8	4.25	30.5	29.8	4.45
1400	0.12	72	47.0	23.0	4.28	44.3	22.1	4.49	41.7	21.2	4.70	38.8	20.3	4.89
		67	38.1	25.4	3.92	40.0	27.2	4.24	36.9	27.2	4.49	34.6	26.6	4.71
		62	36.5	32.9	3.88	35.2	33.2	4.13	33.2	32.6	4.34	31.3	31.3	4.56
1575	0.14	72	47.5	23.9	4.37	44.7	23.0	4.58	41.9	22.0	4.78	39.1	21.1	4.98
		67	37.0	24.8	3.95	38.3	27.8	4.30	37.2	28.5	4.57	35.0	28.1	4.80
		62	35.9	33.0	3.93	35.5	34.5	4.21	33.8	33.7	4.44	32.1	32.1	4.68

50EES-ZP

LEGEND

- BF** — Bypass Factor
- Ewb** — Entering Wet Bulb
- ldb** — Leaving Dry Bulb
- lwb** — Leaving Wet Bulb
- MBtuh** — 1000 Btuh (NET)

3. The sensible heat capacity is based on 80°F edb temperature of air entering indoor coil.
Below 80°F edb, subtract (corr factor x cfm) from the sensible heat capacity.
Above 80°F edb, add (corr factor x cfm) to the sensible heat capacity. Correction Factor = 1.10 x (1-BF) x (edb - 80).

NOTES:

1. Direct interpolation is permissible. Do not extrapolate.
2. The following formulas may be used:

$$t_{ldb} = t_{edw} - \frac{\text{sensible capacity (MBtuh x 1000)}}{1.10 \times \text{cfm}}$$

t_{lwb} = Wet-bulb temperature corresponding to enthalpy of air leaving indoor coil (h_{lwb})

$$h_{lwb} = h_{ewb} - \frac{\text{total capacity (MBtuh x 1000)}}{4.5 \text{ cfm}}$$

Where: h_{ewb} = Enthalpy of air entering indoor coil

Cooling capacities (cont)

50EES 050 - ZP														
EVAPORATOR AIR			CONDENSER AIR TEMPERATURE (F)											
			85			95			105			115		
Cfm	BF	F Ewb	Capacity MBtuh		Compressor kW	Capacity MBtuh		Compressor kW	Capacity MBtuh		Compressor kW	Capacity MBtuh		Compressor kW
			Total	Sensible		Total	Sensible		Total	Sensible		Total	Sensible	
1400	0.06	72	45.0	20.7	4.42	46.7	22.8	4.88	45.5	23.1	5.23	42.6	22.3	5.48
		67	43.8	29.4	4.41	43.6	30.8	4.77	41.1	30.1	5.03	38.1	29.2	5.26
		62	41.7	37.8	4.34	39.6	37.4	4.60	37.1	36.4	4.85	34.6	34.6	5.09
1600	0.07	72	43.2	19.8	4.42	45.9	22.1	4.89	45.8	23.9	5.33	42.9	23.4	5.59
		67	42.2	28.4	4.42	45.5	32.1	4.86	41.5	32.0	5.14	38.5	31.2	5.38
		62	41.5	38.9	4.42	40.1	39.5	4.72	38.0	38.0	4.98	35.7	35.7	5.25
1800	0.08	72	41.5	19.8	4.44	43.6	21.4	4.90	45.1	24.1	5.38	43.2	24.4	5.70
		67	40.7	27.6	4.43	42.7	32.1	3.90	41.7	33.7	5.25	38.7	33.0	5.49
		62	40.1	37.4	4.44	40.5	40.4	4.83	38.9	38.8	5.12	36.7	36.6	5.39

50EES 060 - ZP														
EVAPORATOR AIR			CONDENSER AIR TEMPERATURE (F)											
			85			95			105			115		
Cfm	BF	F Ewb	Capacity MBtuh		Compressor kW	Capacity MBtuh		Compressor kW	Capacity MBtuh		Compressor kW	Capacity MBtuh		Compressor kW
			Total	Sensible		Total	Sensible		Total	Sensible		Total	Sensible	
1750	0.06	72	65.5	30.8	6.22	65.0	31.4	6.78	61.7	30.4	7.22	57.9	29.2	7.60
		67	62.2	41.7	6.16	58.6	40.5	6.55	55.3	39.0	6.87	51.7	37.8	7.27
		62	54.5	48.2	5.80	52.4	47.8	6.21	49.5	46.9	6.60	46.3	45.6	6.97
2000	0.07	72	63.4	30.3	6.23	65.3	32.4	6.90	62.5	32.0	7.38	58.5	30.5	7.75
		67	63.0	44.1	6.30	59.0	43.2	6.72	55.7	41.2	7.01	52.5	40.4	7.43
		62	52.8	47.4	5.82	53.0	50.7	6.35	50.4	49.8	6.76	47.7	47.6	7.17
2250	0.08	72	61.2	29.2	6.23	64.3	32.5	6.95	62.9	33.2	7.51	58.9	31.8	7.88
		67	63.7	46.5	6.43	60.3	45.7	6.86	56.0	43.2	7.14	52.8	42.9	7.57
		62	50.8	46.1	5.84	53.1	52.3	6.47	51.4	51.3	6.93	49.0	49.0	7.37

LEGEND

BF — Bypass Factor
Ewb — Entering Wet Bulb
ldb — Leaving Dry Bulb
lwb — Leaving Wet Bulb
MBtuh — 1000 Btuh (NET)

- The sensible heat capacity is based on 80°F edb temperature of air entering indoor coil.
Below 80°F edb, subtract (corr factor x cfm) from the sensible heat capacity.
Above 80°F edb, add (corr factor x cfm) to the sensible heat capacity. Correction Factor = 1.10 x (1-BF) x (edb - 80).

NOTES:

- Direct interpolation is permissible. Do not extrapolate.
- The following formulas may be used:

$$t_{ldb} = t_{edw} - \frac{\text{sensible capacity (MBtuh x 1000)}}{1.10 \times \text{cfm}}$$

t_{lwb} = Wet-bulb temperature corresponding to enthalpy of air leaving indoor coil (h_{lwb})

$$h_{lwb} = h_{ewb} - \frac{\text{total capacity (MBtuh x 1000)}}{4.5 \text{ cfm}}$$

Where: h_{ewb} = Enthalpy of air entering indoor coil

WET COIL PRESSURE DROP

UNIT SIZE 50EES - ZP	AIRFLOW (cfm)	PRESSURE DROP (in. wg)
035	1000	0.04
	1200	0.05
	1400	0.07
	1600	0.08
040	1000	0.04
	1200	0.05
	1400	0.07
	1600	0.08
050	1400	0.07
	1600	0.08
	1800	0.09
060	1700	0.07
	1800	0.08
	2100	0.09
	2300	0.10

FILTER PRESSURE DROP (in. wg)

UNIT SIZE 50EES	FILTER SIZE (in.)	CFM																	
		700	800	900	1000	1100	1200	1300	1400	1500	1600	1700	1800	1900	2000	2100	2200	2300	
035-040	24 X 24	0.08	0.08	0.09	0.09	0.09	0.10	0.11	0.12	0.14	0.15	—	—	—	—	—	—	—	—
050,060	24 X 30	—	—	—	—	—	—	0.08	0.09	0.10	0.11	0.12	0.13	0.14	0.15	0.16	0.17	0.18	—

ACCESSORY ELECTRIC HEAT PRESSURE DROP (in. wg)

HEATER kW	CFM								
	600	800	1000	1200	1400	1600	1800	2000	2200
5 - 20	0.06	0.08	0.10	0.13	0.15	0.18	0.20	0.23	0.25

DRY COIL AIR DELIVERY* — HORIZONTAL DISCHARGE

UNIT 50EES-ZP	MOTOR SPEED	AIR DELIVERY	400 VOLT HORIZONTAL DISCHARGE								
			External Static Pressure (in.wg)								
			0.1	0.2	0.3	0.4	0.5	0.6	0.7	0.8	0.9
035	Low	Watts	450	435	420	400	380	335	326	311	—
		CFM	1231	1218	1204	1120	1008	950	863	751	—
	Med	Watts	470	450	445	410	388	359	338	321	—
		CFM	1302	1264	1205	1163	1081	940	873	783	—
	High	Watts	660	635	610	575	540	505	485	460	—
		CFM	1700	1660	1581	1450	1297	1190	1095	989	—
040	Low	Watts	478	458	440	411	378	350	327	317	—
		CFM	1303	1270	1224	1179	1126	1022	911	816	—
	Med	Watts	481	468	450	428	404	370	338	320	—
		CFM	1310	1280	1241	1181	1110	102	943	811	—
	High	Watts	—	798	678	647	618	578	540	500	460
		CFM	—	1736	1688	1618	1510	1421	1309	1187	1060
050	Low	Watts	—	—	801	760	730	688	650	600	570
		CFM	—	—	1898	1841	1757	1682	1564	1429	1365
	High	Watts	—	—	870	842	818	782	696	632	628
		CFM	—	—	2000	1903	1799	1718	1625	1446	1333
060	Low	Watts	890	850	810	790	735	680	580	480	422
		CFM	1834	1820	1791	1762	1703	1640	1415	1159	950
	Med	Watts	1040	1018	1000	950	890	835	790	650	580
		CFM	2230	2102	2025	1960	1901	1855	1752	1468	1121
	High	Watts	1073	1038	1001	958	896	840	800	691	575
		CFM	2230	2202	2160	2122	2052	1926	1791	1588	1202

*Air delivery values are based on , dry coil, without filter or electric heater. Deduct wet coil, filter, and electric heater pressure drops to obtain external static pressure available for ducting.

NOTES:

1. Do not operate the unit at a cooling airflow that is less than 350 cfm for each 12,000 Btu/h of rated cooling capacity. Evaporator-coil frosting may occur at airflows below this point.
2. Dashes indicate portions of the table that are beyond the blower motor capacity or are not recommended.

Typical wiring schematic — 360/440 – 3 – 50

SCHEMATIC 400V-3-50

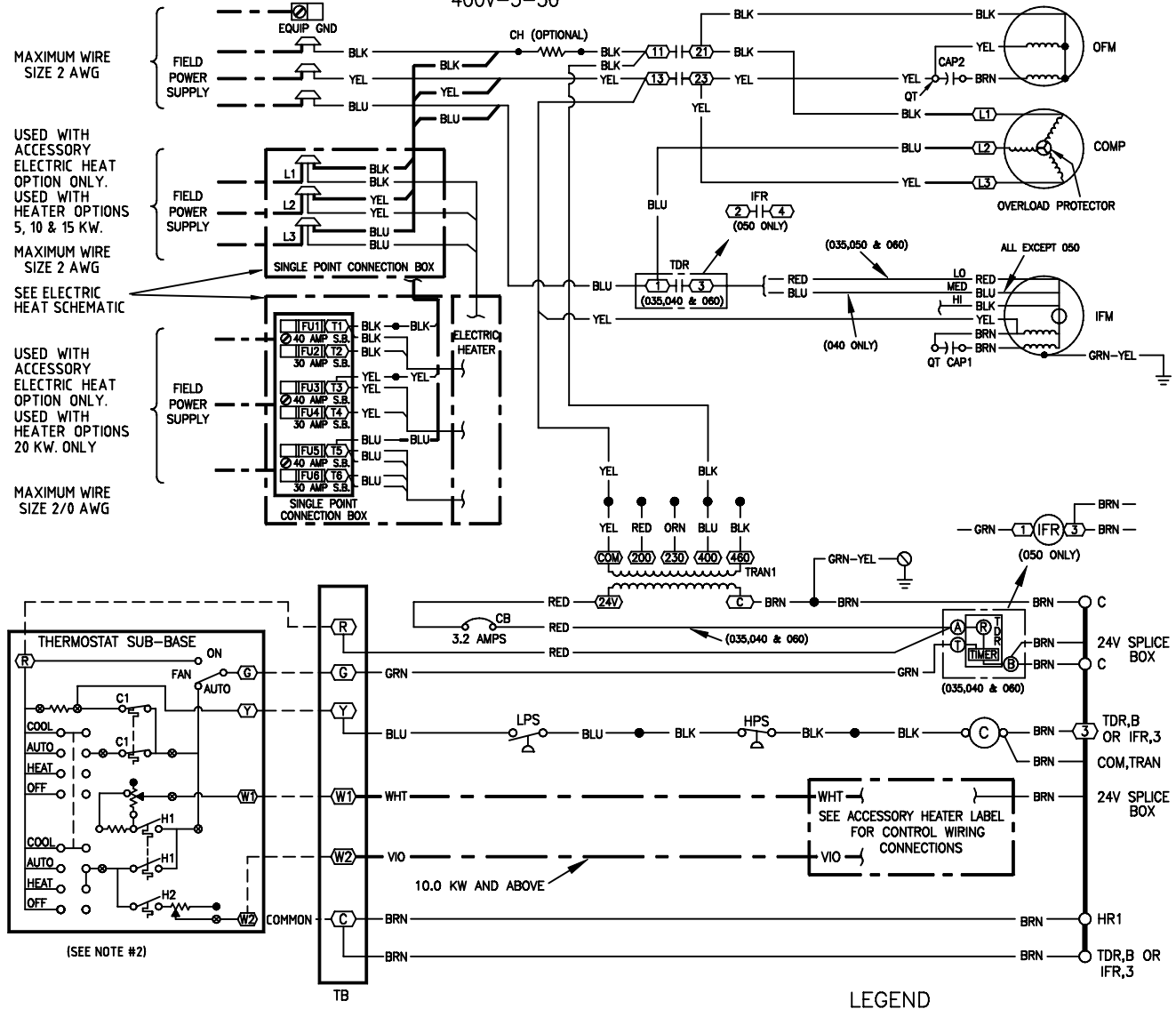

COMPONENT ARRANGEMENT

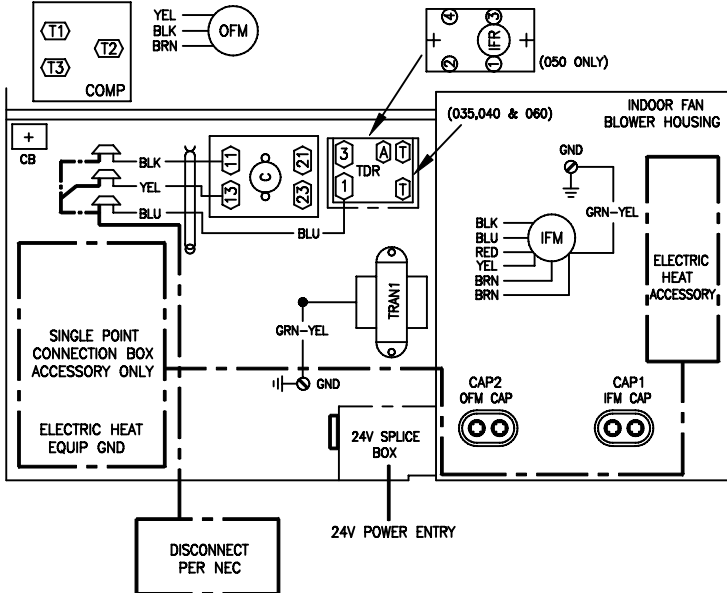

LEGEND

	FIELD SPLICE		CIRCUIT, BREAKER
	MARKED WIRE		CONTACTOR, COMPRESSOR
	TERMINAL (MARKED)		CAPACITOR
	TERMINAL (UNMARKED)		COMPRESSOR MOTOR
	TERMINAL BLOCK		EQUIP
	SPLICE		FUSE LINE
	SPLICE (MARKED)		FUSE
	JUNCTION		GND
	FACTORY WIRING		HR
	FIELD CONTROL WIRING		IFM
	FIELD POWER WIRING		IFR
	ACCESSORY OR OPTIONAL WIRING		IP
	TO INDICATE COMMON POTENTIAL ONLY. NOT TO REPRESENT WIRING		OFM
			QT
			SB
			TB
			TDR
			TH
			TRAN
			CH
			LPS
			HPS

NOTES

- IF ANY OF THE ORIGINAL WIRE FURNISHED MUST BE REPLACED, IT MUST BE REPLACED WITH TYPE 90°C WIRE OR ITS EQUIVALENT.
- SEE PRICE PAGES FOR THERMOSTAT AND SUB BASE PART NUMBERS.
- SET HEAT ANTICIPATOR AT 0.6
- USE 75°C COPPER CONDUCTORS ONLY.

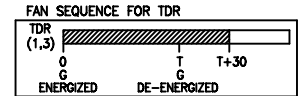

50EES-ZP

Typical field wiring (cont)

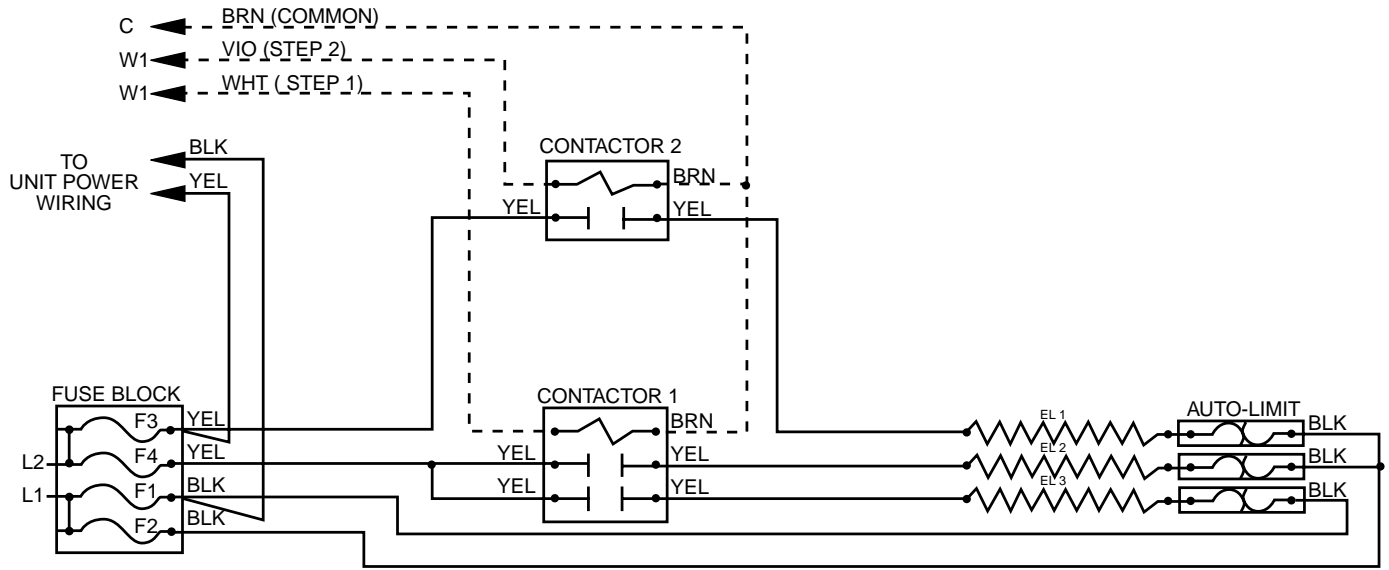

Typical Electric Heater Diagram

50EES-ZP

Electrical data

UNIT 50EES	NOMINAL VOLTAGE (V-Ph-Hz)	VOLTAGE RANGE		COMPRESSOR		OFM	IFM	ELECTRIC HEAT		POWER SUPPLY		
		Min	Max	RLA	LRA	FLA	FLA	Nominal kW*	FLA	MCA	MAX FUSE OR CKT. BKR.	MOCP
035 - ZP	400 - 3 - 50	360	440	5.8	39	1.5	2.8	—/—	—/—	15.4/15.4	25/25	—
								3.8	7.5	17.8/19.9	25/25	
040 - ZP	400 - 3 - 50	360	440	6.3	45	1.5	2.8	—/—	—/—	15.4/15.4	25/25	—
								3.8	7.5	17.8/19.9	25/25	
050 - ZP	400 - 3 - 50	360	440	6.6	53	1.5	4.2	—/—	—/—	21.1/21.1	25/25	—
								3.8	7.5	21.1/21.1	25/25	
060 - ZP	400 - 3 - 50	360	440	9.0	79.0 -	1.4	6.2	—/—	—/—	29.7/29.7	35/35	—
								3.8	7.5	29.7/29.7	35/35	
								7.5	15.3	33.8/37.8	35/40	—

LEGEND

- FLA — Full Load Amps
- HACR — Heating, Air Conditioning and Refrigeration
- IFM — Indoor (Evaporator) Fan Motor
- LRA — Locked Rotor Amps
- MCA — Minimum Circuit Amps
- MOCP — Maximum Overcurrent Protection
- NEC — National Electrical Code
- OFM — Outdoor (Condenser) Fan Motor
- RLA — Rated Load Amps



*Heater capacity (kW) is based on heater voltage of 208 v, 240 v, or 480 v. If power distribution voltage to unit varies from rated heater voltage, heater kW will vary accordingly.
†Fuse or HACR circuit breaker.

NOTES:

1. In compliance with NEC requirements for multimotor and combination load and equipment (refer to NEC Articles 430 and 440), the overcurrent protective device for the unit shall be fuse or HACR breaker.

2. Unbalanced 3-Phase Supply Voltage

Never operate a motor where a phase imbalance in supply voltage is greater than 2%. Use the following formula to determine the percentage of voltage imbalance.

% Voltage Imbalance

$$= 100 \times \frac{\text{max voltage deviation from average voltage}}{\text{average voltage}}$$

Example: Supply voltage is 460-3-60

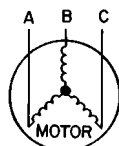

- AB = 452 v
- BC = 464 v
- AC = 455 v

$$\text{Average voltage} = \frac{452 + 464 + 455}{3} = 457$$

Determine maximum deviation from average voltage:

- (AB) 457 - 452 = 5 v
- (BC) 464 - 457 = 7 v
- (AC) 457 - 455 = 2 v

Maximum deviation is 7 v.

Determine percentage of voltage imbalance:

$$\% \text{ Voltage imbalance} = 100 \times \frac{7}{457} = 1.53\%$$

This amount of phase imbalance is satisfactory as it is below the maximum allowable 2%.

IMPORTANT: If the supply voltage phase imbalance is more than 2% contact your local electric utility company immediately.

Operating sequence

COOLING

NOTE: With the FAN switch in the ON position, 24 v is supplied to the time-delay relay (TDR) through the G terminal on the thermostat. This voltage energizes the coil of the relay, closing the normally-open set of contacts which provide continuous power to the indoor (evaporator) fan motor (IFM). Moving the FAN switch back to the AUTO position (providing there is not a call for cooling) deenergizes the TDR (when applicable) which deenergizes the IFM after a 30-second delay. The FAN switch in AUTO position cycles upon a call for cooling.

On a call for cooling, 24 v is supplied to the compressor contactor (C) and TDR simultaneously through the Y and G terminals of the thermostat, respectively. On units with a compressor TDR, there is a built-in, 5-minute (± 45 seconds) delay between compressor starts. Energizing the contactor closes the normally-open set of contacts supplying power to both the compressor and outdoor (condenser) fan motor (OFM). Energizing the TDR closes the normally-open set of contacts providing power to the IFM. On the loss of the call for cooling, 24 v is removed from both the Y and G terminals of the thermostat (providing the FAN switch is in the AUTO position), deenergizing both the compressor and TDR and opening both the contacts supplying power to compressor/OFM. IFM has a 30-second delay.

HEATING

When power is supplied to unit, transformer (TRAN) is energized. On units with crankcase heater (CH), heater is also energized.

With thermostat set to call for heating, sequence of operation is as follows:

On a call for heat, circuit R-W and R-G are made through first-stage thermostat bulb. If accessory electric heaters are used, a relay is energized, bringing on first stage of supplemental electric heat and fan. When thermostat is satisfied, contacts open, deenergizing relay (on all units) and time-delay relay (on units equipped with time-delay relay). Heaters deenergize, and evaporator fan stops after a 30-second time delay (on units equipped with time-delay relay).

50EES-ZP

Typical Installation

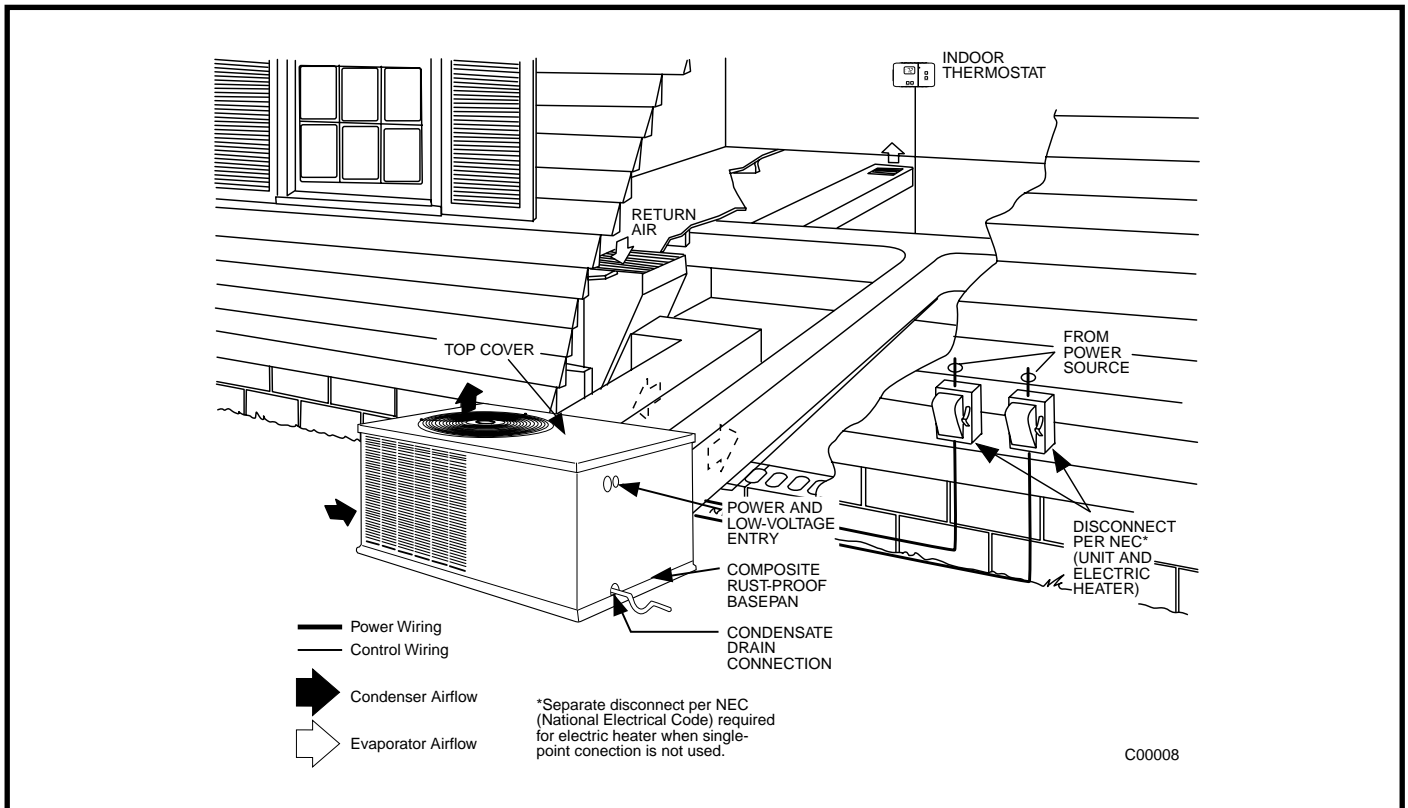

APPLICATION DATA ACCESSORY ELECTRIC HEATERS

ODS CATALOG ORDERING NO.	NOMINAL CAPACITY (kW)	USED WITH SIZES			
		035	040	050	060
ELECTRIC HEATERS (400 v — 3 PHASE — 50 Hz)					
CPHEATER034A00	5.0	X	X	X	X
CPHEATER035A00	10.0	X	X	X	X

LEGEND

ODS — Order Distribution System

NOTE: Electric heaters are rated at 480 v. Refer to Multiplication Factors table below for voltages in other applications.

MULTIPLICATION FACTORS

HEATER kW RATING	VOLTAGE DISTRIBUTION V/3/60	MULTIPLICATION FACTOR
450	400	0.75
	440	0.84
	460	0.92
	480	1.00

Example: 10.0 kW (at 480v) heater on 400 v
 = 10.0 (.75 mult factor)
 = 7.5 capacity at 400 v

Engineers' specification guide

GENERAL: Furnish and install outdoor package, electrically controlled, air conditioner utilizing a reciprocating compressor for cooling duty. Unit shall discharge supply air horizontally.

Nominal unit electrical characteristics shall be _____ v, _____ ph, 50 Hz. The unit shall be capable of satisfactory operation within voltage limits of _____ v to _____ v. Unit power wiring shall enter unit cabinet at a single location. Separate power supply shall not be required for electric heat.

COOLING CAPACITY: Total cooling capacity of the unit shall be _____ Btuh or greater, and sensible capacity shall be _____ Btuh or greater at conditions of _____ cfm indoor air entering unit at _____ F dry bulb, _____ F wet bulb and outdoor entering air of _____ F dry bulb. Total design conditions shall be a minimum of _____ Btuh/Watt. The unit shall be capable of cooling operation down to 40 F as shipped from the factory.

CABINET: Unit cabinet shall be constructed of galvanized, minimum spangle G90, powder painted steel. Basepan shall be made of a single-piece non-corrosive, composite material.

Evaporator-fan compartment interior cabinet surfaces shall be insulated with a minimum 1/2-in. thick, flexible fiberglass insulation, coated on the air side with aluminum foil.

Cabinet panels shall be easily removable for servicing.

Outdoor coil shall be protected by metal louvered panels.

COMPRESSOR: Compressor shall be fully hermetic type with internal and external vibration isolation.

CONDENSER SECTION: Condenser fan shall be of the direct-driven propeller type with aluminum blades, riveted to corrosion-resistant steel spiders, and shall be dynamically balanced and discharge air vertically upwards.

Condenser coils shall have aluminum-plate fins mechanically bonded to seamless copper tubes with all joints brazed.

Tube sheet openings shall be belled to prevent tube wear.

EVAPORATOR SECTION: Fan shall be 2- or 3-speed with direct drive motor as shown on the equipment drawings.

Fan wheel shall be made from steel, be double-inlet type with forward-curved blades with a corrosion-resistant finish and dynamically balanced.

Evaporator coils shall have aluminum-plate fins mechanically bonded to seamless copper tubes with all joints brazed.

Tube sheet openings shall be belled to prevent tube wear.

MOTORS: Compressor motors shall be of the refrigerant-cooled type with line break thermal and current overload protection.

All fan motors shall have permanently lubricated bearings, and inherent automatic reset thermal overload protection.

Condenser fan motor shall be open drip-proof.

REFRIGERANT SYSTEM: Refrigerant system shall include fixed orifice metering system.

CONTROLS: Unit shall be complete with self-contained low-voltage control circuit.

APPROVALS: Unit shall be UL listed as a total package for safety requirements. All wiring shall be in accordance with NEC.

Unit shall be rated in accordance with ARI Standards 210/240-89 and 270-84.

Cabinet insulation shall conform to ASHRAE No. 62P.

Insulation and adhesive shall meet NFPA 90A requirements for flame spread and smoke generation.

Unit shall have a sloped drain pan that conforms to ASHRAE Standard 62-89.

ACCESSORIES: Field-installed accessories shall include solid-state compressor short-cycle device, outdoor thermostat, thermostat and subbase, electric heaters with single-point connection, crankcase heater, low- and high-pressure switch kits, and low-ambient kit.

NOTES



Turn to the Experts™

Manufacturer reserves the right to discontinue, or change at any time, specifications or designs without notice and without incurring obligations